

Chemistry ATAR Year 12

Maximise Performance.



Achieve Success.

Since 1986 ACADEMIC TASK FORCE has helped over
100,000 students boost their academic results.

PO BOX 627, APPLECROSS WA 6953
Phone: 08 9314 9500 Fax: 08 9314 9555
learn@academictaskforce.com.au
www.academicassociates.com.au
www.academictaskforce.com.au

perthchemist@gmail.com

Do you want to Achieve Success at School? WE CAN HELP YOU

A+

ATAR Revision Program

Specially designed programs to help revise ATAR course content and teach students how to maximise their results. Held in the January, April, July and October school holidays



Master Classes

Weekly teaching classes by expert ATAR teachers who aim to extend and teach students how to gain maximum marks.



Weekend Tuition Classes

Small group tutoring classes available throughout the year to provide on-going help as you need it. For years 7 - 12.



Head Start Program

Held in January for Years 7-12 so students can fill in gaps in their learning and build understanding in their subjects to start the new year with confidence.



Skills Development Program

Held in April, July and October for years 7-10 to help students revise important concepts and skills.



Individual Tuition

In your own home or boarding school. All ages, all areas.

For more information please contact:

Phone: 9314 9500 **Email:** learn@academictaskforce.com.au

Visit **ACADEMIC TASK FORCE:** www.academictaskforce.com.au



PO BOX 627, APPLECROSS WA 6953
Phone: 08 9314 9500 Fax: 08 9314 9555
learn@academictaskforce.com.au
www.academicassociates.com.au
www.academictaskforce.com.au

Yr 12 Chemistry Unit 3 2016.

Syllabus Notes & Past Examination Questions

Lyndon Smith

Chemistry Syllabus 2016

Unit 3

Equilibrium, acids and bases, and redox reactions

Unit content

Science Inquiry Skills

- identify, research, construct and refine questions for investigation; propose hypotheses; and predict possible outcomes
- design investigations, including the procedure(s) to be followed, the materials required, and the type and amount of primary and/or secondary data to be collected; conduct risk assessments; and consider research ethics
- conduct investigations safely, competently and methodically for the collection of valid and reliable data, including: acid-base properties, using acid-base volumetric analysis techniques, effects of changes to equilibrium systems, and constructing electrochemical cells
- represent data in meaningful and useful ways, including using appropriate graphic representations and correct units and symbols; organise and process data to identify trends, patterns and relationships; identify and distinguish between random and systematic errors, and estimate their effect on measured results; discuss how the nature of the procedure and the sample size may influence uncertainty and limitations in data; and select, synthesise and use evidence to make and justify conclusions
- interpret a range of scientific texts, and evaluate processes, claims and conclusions by considering the quality of available evidence, including confidence intervals in secondary data; and use reasoning to construct scientific arguments
- communicate to specific audiences and for specific purposes using appropriate language, nomenclature and formats, including scientific reports

Science as a Human Endeavour

Chemical equilibrium systems

Levels of carbon dioxide in the atmosphere are rising and have a significant impact on global systems, including surface temperatures. The increasing level of carbon dioxide in the atmosphere causes more carbon dioxide to dissolve in the ocean producing carbonic acid and leading to increased ocean acidity. This is predicted to have a range of negative consequences for marine ecosystems such as coral reefs. Calcification is the process which results in the formation of calcium carbonate structures in marine organisms. Acidification shifts the equilibrium of carbonate chemistry in seawater, decreasing the rate and amount of calcification among a wide range of marine organisms. The United Nations Kyoto Protocol and the Intergovernmental Panel on Climate Change aim to secure a global commitment to reducing greenhouse gas emissions over the next few decades.

Science Understanding

- collision theory can be used to explain and predict the effects of concentration, temperature, pressure, the presence of catalysts and surface area of reactants on the rates of chemical reactions
- chemical systems include physical changes and chemical reactions and may be open (which allow matter and energy to be exchanged with the surroundings) or closed (which allow energy, but not matter, to be exchanged with the surroundings)
- observable changes in chemical reactions and physical changes can be described and explained at an atomic and molecular level
- over time, in a closed system, reversible physical and chemical changes may reach a state of dynamic equilibrium, with the relative concentrations of products and reactants defining the position of equilibrium
- the characteristics of a system in dynamic equilibrium can be described and explained in terms of reaction rates and macroscopic properties
- the reversibility of chemical reactions can be explained in terms of the activation energies of the forward and reverse reactions
- the effect of changes of temperature on chemical systems initially at equilibrium can be predicted by considering the enthalpy changes for the forward and reverse reactions; this can be represented on energy profile diagrams and explained by the changes in the rates of the forward and reverse reactions
- the effects of changes in concentration of solutions and partial pressures of gases on chemical systems initially at equilibrium can be predicted and explained by applying collision theory to the forward and reverse reactions
- the effects of changes in temperature, concentration of species in solution, partial pressures of gases, total volume and the addition of a catalyst on equilibrium systems can be predicted using Le Châtelier's Principle
- equilibrium law expressions can be written for homogeneous and heterogeneous systems; the equilibrium constant (K), at any given temperature, indicates the relationship between product and reactant concentrations at equilibrium
- the relative amounts of reactants and products (equilibrium position) can be predicted qualitatively using equilibrium constants (K_c)

Science as a Human Endeavour

Acids and bases

Models and theories are contested and refined or replaced when new evidence challenges them, or when a new model or theory has greater explanatory scope. Davy initially proposed that acids were substances that contained replaceable hydrogen (hydrogen that could be partly or totally replaced by metals) and bases were substances that reacted with acids to form salts and water. The Arrhenius model, which includes only soluble acids and bases, identified acids as substances which produce hydrogen ions in solution and bases as substances which produce hydroxide ions in solution. Subsequently, the Brønsted-Lowry model describes acid-base behaviour in terms of proton donors and proton acceptors. This approach includes a wider range of substances and can be more broadly applied.

Science Understanding

- acids are substances that can act as proton (hydrogen ion) donors and can be classified as monoprotic or polyprotic, depending on the number of protons available for donation

- the strength of acids is explained by the degree of ionisation at equilibrium in aqueous solution which can be represented by chemical equations and acidity constants (K_a)
- the relationship between acids and bases in equilibrium systems can be explained using the Brønsted-Lowry model and represented using chemical equations that illustrate the transfer of protons between conjugate acid-base pairs
- the hydrolysis of salts of weak acids and weak bases can be represented using equations; the Brønsted-Lowry model can be applied to explain the acidic, basic and neutral nature of salts derived from bases and monoprotic and polyprotic acids
- buffer solutions are conjugate in nature and resist changes in pH when small amounts of strong acid or base are added to the solution; buffering capacity can be explained qualitatively; Le Châtelier's Principle can be applied to predict how buffers respond to the addition of hydrogen ions and hydroxide ions
- water is a weak electrolyte; the self-ionisation of water is represented by $K_w = [H^+][OH^-]$ where $K_w = 1.0 \times 10^{-14}$ at 25 °C
- K_w can be used to calculate the concentration of hydrogen ions or hydroxide ions in solutions of strong acids or bases
- the pH scale is a logarithmic scale and the pH of a solution can be calculated from the concentration of hydrogen ions using the relationship $pH = -\log_{10} [H^+]$
- acid-base indicators are weak acids, or weak bases, in which the acidic form is a different colour from the basic form
- volumetric analysis methods involving acid-base reactions rely on the identification of an equivalence point by measuring the associated change in pH, using appropriate acid-base indicators or pH meters, to reveal an observable end point
- data obtained from acid-base titrations can be used to calculate the masses of substances and concentrations and volumes of solutions involved

Science as a Human Endeavour

Oxidation and reduction

Spontaneous redox reactions can be used as a source of electrical energy, including primary, secondary and fuel cells. Fuel cells are a potential lower-emission alternative to the internal combustion engine and are already being used to power various modes of transport. Organisations, including the International Partnership for Hydrogen and Fuel Cells in the Economy, have been created to foster global cooperation on research and development, common codes and standards, and information sharing on infrastructure development.

Science Understanding

- oxidation-reduction (redox) reactions involve the transfer of one or more electrons from one species to another
- oxidation involves the loss of electrons from a chemical species, and reduction involves the gain of electrons by a chemical species; these processes can be represented using half-equations and redox equations (acidic conditions only)
- a range of reactions involve the oxidation of one species and reduction of another species, including metal and halogen displacement reactions, combustion and corrosion
- the species being oxidised and reduced in a redox reaction can be identified using oxidation numbers
- the relative strength of oxidising and reducing agents can be determined by comparing standard electrode potentials, and can be used to predict reaction tendency
- electrochemical cells, including galvanic and electrolytic cells, consist of oxidation and reduction half-reactions connected via an external circuit through which electrons move from the anode (oxidation reaction) to the cathode (reduction reaction)
- galvanic cells produce an electric current from a spontaneous redox reaction
- the electric potential difference of a cell under standard conditions can be calculated from standard electrode potentials; these values can be used to compare the voltages generated by cells constructed from different materials
- electrochemical cells can be described in terms of the reactions occurring at the anode and cathode, the role of the electrolyte, salt bridge (galvanic cell), ion migration, and electron flow in the external circuit
- cell diagrams can be used to represent electrochemical cells
- electrolytic cells use an external electrical potential difference to provide the energy to allow a non-spontaneous redox reaction to occur; electrolytic cells are used in a range of industrial situations, including metal plating and the purification of copper
 - write ionic equations using ions in the list below:

	Ion name	Formula
Al ³⁺	aluminium	Al ³⁺
NH ₄ ⁺	ammonium-	NH ₄ ⁺
Ba ²⁺	barium	Ba ²⁺
Br ⁻	bromide	Br ⁻
Cs ⁺	caesium	Cs ⁺
Ca ²⁺	calcium	Ca ²⁺
(CO ₃) ²⁻	carbonate	CO ₃ ²⁻
Cl ⁻	chloride	Cl ⁻
(CrO ₄) ²⁻	chromate	CrO ₄ ²⁻
Cr ³⁺	chromium(III)	Cr ³⁺
Co ²⁺	cobalt(II)	Co ²⁺
Cu ²⁺	copper(II)	Cu ²⁺
CN ⁻	cyanide	CN ⁻
(Cr ₂ O ₇) ²⁻	dichromate	Cr ₂ O ₇ ²⁻
H ₂ PO ₄ ⁻	dihydrogenphosphate	H ₂ PO ₄ ⁻
H ₃ COO ⁻	ethanoate (acetate)	CH ₃ COO ⁻
F ⁻	fluoride	F ⁻
H ⁺	hydrogen	H ⁺
HCO ₃ ⁻	hydrogencarbonate	HCO ₃ ⁻
HPO ₄ ²⁻	hydrogenphosphate	HPO ₄ ²⁻
HSO ₄ ⁻	hydrogensulfate	HSO ₄ ⁻
OH ⁻	hydroxide	OH ⁻
I ⁻	iodide	I ⁻
Fe ²⁺	iron(II)	Fe ²⁺
Fe ³⁺	iron(III)	Fe ³⁺
Pb ²⁺	lead(II)	Pb ²⁺
Li ⁺	lithium	Li ⁺
Mg ²⁺	magnesium	Mg ²⁺
Mn ²⁺	manganese(II)	Mn ²⁺
Ni ²⁺	nickel(II)	Ni ²⁺
NO ₃ ⁻	nitrate	NO ₃ ⁻
N ³⁻	nitride	N ³⁻
NO ₂ ⁻	nitrite	NO ₂ ⁻
(C ₂ O ₄) ²⁻	oxalate	C ₂ O ₄ ²⁻
O ²⁻	oxide	O ²⁻
MnO ₄ ⁻	permanganate	MnO ₄ ⁻
PO ₄ ³⁻	phosphate	PO ₄ ³⁻
K ⁺	potassium	K ⁺
Rb ⁺	rubidium	Rb ⁺
Ag ⁺	silver	Ag ⁺
Na ⁺	sodium	Na ⁺
	strontium	Sr ²⁺
SO ₄ ²⁻	sulfate	SO ₄ ²⁻

S ²⁻	sulfide	S ²⁻
SO ₃ ²⁻	sulfite	SO ₃ ²⁻
Zn ²⁺	zinc	Zn ²⁺

- write the molecular formulae of commonly encountered molecules that have non-systematic names including NH₃, H₂O, H₂O₂, CH₃COOH, HC□, HNO₃, H₂CO₃, H₂SO₄, H₂SO₃, H₃PO₄

Chemistry Study Tips

General Study Tips

1. You need a quiet place to work. It might be a bedroom. You need a space where you can lay out books and where you can store them. You will need good ventilation and lighting.
2. Despite what you might think you cannot concentrate with music, television, Facebook, SMS etc. Remove them when you are going to work. Despite what you might think, there are plenty of research studies that show you cannot learn in a distracted environment.
3. Make your study routine a regular habit. Set aside regular times and each day work on all your subjects. Get your homework done each day and do some study as well.

Preparing for the Chemistry Exam

1. The very first thing to do is obtain a copy of the syllabus [your teacher would have given you one] and read it. The text book is not the syllabus and neither is what your teacher said. The exam is based on the syllabus.
2. Learn the basics. Some examples : simple algebra metric prefixes milli, kilo, tonne, ppm etc., significant figures, temperature conversions (Celsius, Kelvin), chemical symbols listed in the syllabus – it is disappointing how many year 12 students don't know sulfate/sulfite/sulfide and cannot balance equations. You should be able to convert between milligrams, grams and kilograms and millilitres and litres without the conversion factor being supplied.
3. Learn the symbols of chemistry. The syllabus includes a list of 57 molecules and ions. Because they are in the syllabus we assume you know them. Thus we can ask questions like "hydrogen peroxide reacts with acidified permanganate ion" and if you cannot correctly write the equation, you cannot start with the stoichiometry and score very poorly.
4. Learn and practice the terminology. If a term is used in the syllabus you are expected to know what it means. You will never be asked for a definition but you will need to use definitions to understand questions. Be conversant with the terms used in the syllabus, e.g., ionisation energy, trend, polarities, partial pressures, chemical test, polymerisation, origin of intermolecular interactions, hydrolysis. Know the fine distinctions between related words, such as clear and colourless; intermolecular force and intramolecular force; equivalence point and end point.
5. Chemistry is a subject you study by doing. Make problem solving a part of every study session. Your ability to solve problems increases with practice. The more you review and work out problems, the more you will be able to put it all together in an exam.
6. Learn how to use your calculator. You must be able to convert pH to $[H^+]$ and back again without error. You cannot express pH as an exponent. Can you convert $[H^+]$ to $[OH^-]$? Far too many students arrive at wrong answers because of faulty calculator use rather than errors in chemistry.
7. The Periodic Table is central to your understanding of chemistry. Knowing how it works will make your understanding deeper. Learn generalizations. These may be useful for explaining chemical phenomena and for predicting new relationships and new facts.
8. The syllabus has 3 sections – Science Understanding, Science Enquiry Skills and Science as a Human Endeavour. Do not ignore SIS - know how to generate, read and apply data from graphs and tables
9. Use at least 2 different chemistry books when studying. Each book will explain it in different words and it will be like having different teachers explaining it to you. If one doesn't make sense, the other book might!
10. Begin your exam revision early. This is not a subject where you can regurgitate crammed facts. Give yourself your own timed exams. Test yourself until you can get 100% repeatedly on your own difficult

exams. Use these tests to find out what you don't know and practise these areas.

11. Where possible include past papers in your study. While the syllabus has changed from the TEE, and the WACE there are still a larger percentage of the questions that are relevant.
12. Practise writing clear, concise and coherent extended answers and incorporating illustrative, labelled diagrams that are clear and relevant.
13. Be familiar with the contents of, and how to use, the Chemistry Data Booklet; and know where to find the information it contains quickly.
14. Maintain brain and body stamina. Maintain an alert mind and a happy, positive attitude. Take care of your diet and your sleep before the exam. Get 7 to 8 hours of sleep in the nights before. Do not "cram". You will be slow and not think clearly.

Some Points on taking the exam

1. Perhaps the most important piece of advice is: Think before you write! Much precious time can be saved by spending a few seconds contemplating your answer before you spend the time to write it out. Your brain generally works much faster than your pen.
2. Examine all the problems first before you begin any of them. Do the problems you know first, saving the problems that will require more work for later. You have a limited period of time in which to earn your marks, so do the problems on which you will get the most marks first.
3. The examination is written using the 90/90 rule. Ninety percent of the candidates should finish in ninety percent of the time. You need to work efficiently but not rush.
4. Equations are the language of chemistry. Write them often and include them in explanations even if they are not specifically asked for.
5. Write neatly. If your words cannot be understood, you will not get credit for them. Markers are not expected to labour over scribble.
6. Spell chemical words correctly. Although this is not an English course, part of learning a subject is mastery of the vocabulary. In addition, be careful with your choice of words. Chemistry vocabulary is large because there are so many words that have very specific meanings. e.g. "Deliquescent" is not the same as "Hygroscopic".
7. The exam paper has space for your answer. The number of lines has been very carefully worked out. If you do not fill it, or need more space, there is probably something wrong with your answer.
8. You might find a question about something you have not been taught. Don't panic. Think "What part of the course is this question about?" What are the underlying key concepts?
9. Plan your answer. Avoid writing down points in random order as they come to you. Pack as much information into the answer as possible, but avoid irrelevant information. The number and accuracy of relevant concepts is more important than the number of words.
10. From my experience many students do not read the question carefully. They read only key words and miss the context and the adjectives. Remember every word in the question has been put there for a purpose.
11. Always read the first word of the question very carefully. Make sure you know what the question is asking. Words might be "list" or "describe". There is a reason that particular word has been chosen. If it says "circle and label," then circle AND label. Other often ignored instructions are "include a diagram", "label the axes", "show the movement of ions" and "include an equation".
12. Equilibrium questions. If an equilibrium question asks you to "predict" rather than "explain", your answer will be different. Note that Le Châtelier's Principle is a predicting tool not an explanation.

Distinguish between the use of:

- collision theory to explain the changes in forward and backward rates of reaction
 - the change in rates of the forward and reverse reactions to determine and explain the effect on equilibrium position
 - Le Châtelier's Principle to predict the impact of changing conditions to a system on its chemical equilibrium.
13. "A" grade students construct coherent paragraphs that use correct chemistry terms in a logical sequence for questions requiring explanations. Markers will not interpret poorly structured sentences and make up an answer for you.
 14. Always write ionic equations and include the (*aq*) or (*g*) etc. in the expression.
 15. If you are asked to describe observations remember observations include gas formation, precipitates, colour, smell and temperature. Use meaningful adjectives to describe the observations – e.g. a fruity/sweet smell not a "strong smell" or a "nice smell".. You cannot observe "hydrogen gas". You can observe "a colourless, odourless gas"
 16. You must be able to convert a word equation into a balanced symbol equation. Read the sentence carefully and note oxidation states like iron III rather than iron II. When writing REDOX half equations remember that there must be one oxidant and one reductant.
 17. Some students have a prepared answer in mind and deliver it whether the question asks for it or not. This technique might earn you no marks at all and use up a lot of time. Answer questions with specific reference to what the question demands rather than as a generalisation or implication. Candidates are not necessarily awarded any marks for correct chemistry unless it pertains specifically to the question asked.
 18. You might have been told in grade two to rewrite the question in the answer. Don't - it earns you no marks and costs you time.
 19. Do not leave a question blank. Write a part answer. It might earn you part marks.
 20. The examination questions will not be in the order of the chapters in your book and will not be restricted to just one chapter. e.g. hydrogen bonding between organic molecules.
 21. Equilibrium equations use equilibrium arrows.
 22. When answering a calculation question show all your working. Label answers along the way. Markers cannot sort through a mess of random numbers to try to make sense of a wrong calculation. Show your working and reasoning very clearly in such questions and you might earn part marks for a wrong answer.
 23. Make it a habit to use the appropriate units and express numerical answers to the appropriate significant figures. The old syllabus specified 3 sig figs but your syllabus specifies "appropriate sig figs). Check the data!
 24. Don't read the multiple choice questions during the reading time until you have read Sections 2 and 3. Reading time for multiple choice is included in the time allocation for that section

Do you know ALL your ions and molecules ?

acetic acid	CH_3COOH
aluminium ion	Al^{3+}
ammonia	NH_3
ammonium ion	NH_4^+
barium ion	Ba^{2+}
bromide ion	Br^-
caesium ion	Cs^+
calcium ion	Ca^{2+}
carbonate ion	CO_3^{2-}
carbonic acid	H_2CO_3
chloride ion	Cl^-
chromate ion	CrO_4^{2-}
chromium(III) ion	Cr^{3+}
cobalt(II) ion	Co^{2+}
copper(II) ion	Cu^{2+}
cyanide ion	CN^-
dichromate ion	$\text{Cr}_2\text{O}_7^{2-}$
dihydrogenphosphate ion	H_2PO_4^-
ethanoate (acetate) ion	CH_3COO^-
fluoride ion	F^-
hydrochloric acid	HCl
hydrogen ion	H^+
hydrogen peroxide	H_2O_2
hydrogencarbonate ion	HCO_3^-
hydrogenphosphate ion	HPO_4^{2-}
hydrogensulfate ion	HSO_4^-
hydroxide ion	OH^-
iodide ion	I^-
iron(II) ion	Fe^{2+}
iron(III) ion	Fe^{3+}

lead(II) ion	Pb^{2+}
lithium ion	Li^+
magnesium ion	Mg^{2+}
manganese(II) ion	Mn^{2+}
nickel (II) ion	Ni^{2+}
nitrate ion	NO_3^-
nitric acid	HNO_3
nitride ion	N^{3-}
nitrite ion	NO_2^-
oxalate ion	$\text{C}_2\text{O}_4^{2-}$
oxide ion	O^{2-}
permanganate ion	MnO_4^-
phosphate ion	PO_4^{3-}
phosphoric acid	H_3PO_4
potassium ion	K^+
rubidium ion	Rb^+
silver ion	Ag^+
sodium ion	Na^+
strontium ion	Sr^{2+}
sulfate ion	SO_4^{2-}
sulfide ion	S^{2-}
sulfite ion	SO_3^{2-}
sulfuric acid	H_2SO_4
sulfurous acid	H_2SO_3
water	H_2O
zinc ion	Zn^{2+}

Chemical equilibrium systems

Science Understanding

collision theory can be used to explain and predict the effects of concentration, temperature, pressure, the presence of catalysts and surface area of reactants on the rates of chemical reactions

Note : When asked a question involving rate e.g. "why do reactions go faster when hot?" it is **NOT** sufficient to say "Temperature". You must talk about collisions and the proportion of particles with sufficient E_a .

DEFINITION

The speed at which reactions occur is called the Rate of Reaction.

$$\text{Rate} = \frac{\Delta n}{\Delta t} \text{ or Rate} = \frac{\text{change in concentration}}{\text{time taken}} = \frac{\Delta C}{\Delta t}$$

Rate of reaction depends on the frequency of successful collision per volume per second.

Rate of Reaction Graphically

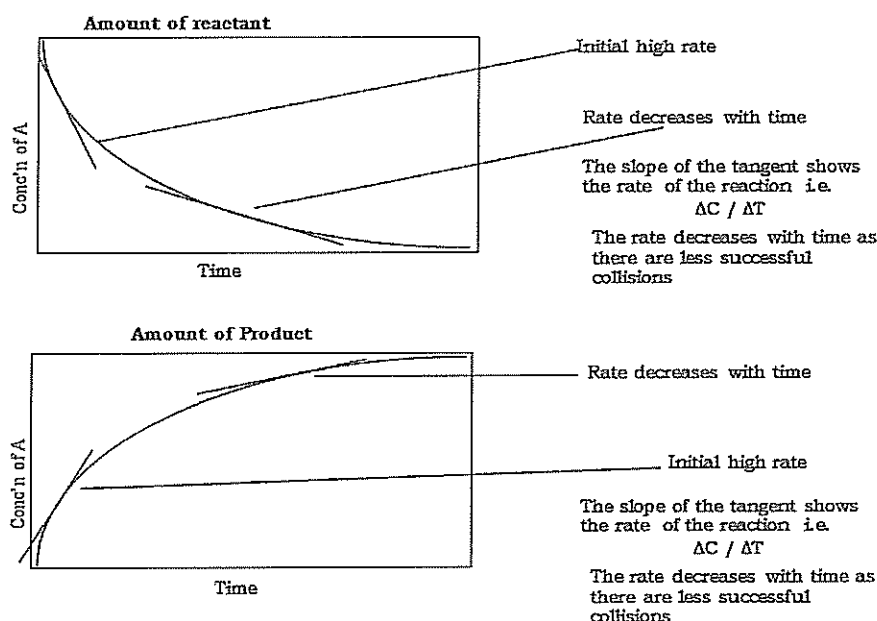

The nature of the reactants - what is reacting ions in solution are generally fast reactions. Reactions involving the breaking of covalent bonds and the reforming of new bonds are generally slow

The presence of catalysts

- catalysts provide an alternative pathway [alternative reaction] of lower activation energy
DO NOT JUST SAY *THEY SPEED UP REACTIONS AND THEY DO NOT* "Lower E_a "
Special case of catalysts are enzymes (rates increase up to 10^6 times). Needed in living creatures because we are cold 37°C while industry works at temperatures like 500°C
- selective to one reaction
- work at mild temperatures
- are pH sensitive

Catalysts and Activation Energy

- Catalysts increase the rate of a reaction by helping break chemical bonds in reactant molecules.
- This effectively means the activation energy is reduced.
- Therefore at the same temperature, more reactant molecules have enough kinetic energy to react compared to the un-catalysed situation and so the reaction speeds up with the greater chance of a 'fruitful' collision.
- Note that a catalyst does NOT change the energy of the molecules; it reduces the threshold kinetic energy needed for molecules to react by offering a new pathway.
- Although a true catalyst does take part in the reaction, it does not get used up and can be reused with more reactants; it may change chemically on a temporary basis but would be reformed as the reaction products also form.

- However a solid catalyst might change physically permanently by becoming more finely divided, especially if the reaction is exothermic.
- Also note from the diagram that although the activation energy is reduced, the overall exothermic or endothermic energy change is the same for both the catalysed or uncatalysed reaction. The catalyst might help break the bonds BUT it cannot change the actual bond energies.

Temperature

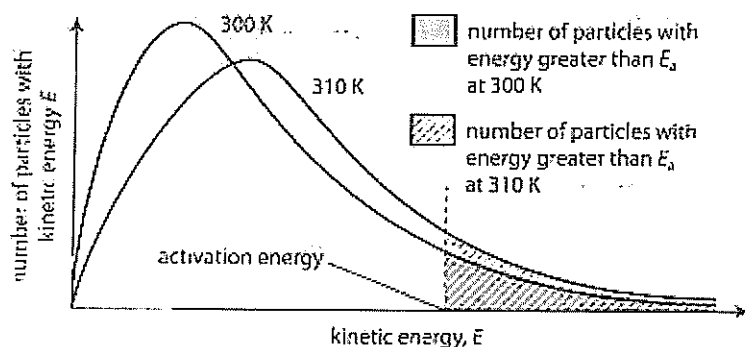

Maxwell-Boltzmann distribution

temperature has two effects

1. Kinetic Energy \rightarrow Activation Energy
 - the higher the temperature the higher the average Kinetic Energy
 - particles with sufficient KE can react - this is called the activation energy.- E_a
2. more Kinetic Energy \rightarrow more collisions and more successful collisions
 - for particles to react they must collide. The higher the temperature the more collisions/sec

Pressure

- the concentration of the reactants (for gaseous reaction : the pressure of the gas mixture)
Higher concentrations give higher numbers of collisions/sec

State of sub-division

- the state of subdivision : the size of the particles wood burns, sugar dissolves etc. the higher surface area means there can be more collisions/sec

chemical systems include physical changes and chemical reactions and may be open (which allow matter and energy to be exchanged with the surroundings) or closed (which allow energy, but not matter, to be exchanged with the surroundings)

Open and closed and isolated systems

An open system is one whose borders allow the movement of energy and matter into and out of the system. e.g. an open bottle of soft drink

A closed system is one in which only energy can be exchanged, but not matter. e.g. a closed bottle of soft drink

An isolated system allows neither energy nor matter to enter or leave. e.g. An insulated, closed bottle of soft drink

observable changes in chemical reactions and physical changes can be described and explained at an atomic and molecular level

over time, in a closed system, reversible physical and chemical changes may reach a state of dynamic equilibrium, with the relative concentrations of products and reactants defining the position of equilibrium

Reversible reactions - those reactions that can go in a forward and a backward direction

e.g.

- the solution process. When sugar dissolves in water the sugar molecules are in random motion some come back into contact with the un-dissolved sugar crystals and become part of the structure once more
- a solid dissolving has more particles going into solution than coming out (forward reaction)
- a solid precipitating has more particles coming out of solution than going in (reverse reaction)
- saturated solution has as many particles going into solution as are coming out, thus it has reached an equilibrium

Dynamic-Equilibrium

The speed of a forward reaction will be initially high when the reactants react. This is because their concentrations are high. The speed of the reverse reaction will be zero until some products form. As more products form, the speed of the reverse reaction increases. Finally there comes a time when the speed of the forward reaction is balanced by the speed of the reverse reaction => **dynamic equilibrium**

Equilibrium

when there is no change in macroscopic properties of the system. These reactions are continuously forming products and reactants

Characteristics of a dynamic equilibrium in chemical reactions ;

the macroscopic properties remain constant under a given set of conditions for the reaction. Thus, to the observer there is no observable change in such properties as colour, concentration, pressure and temperature.

microscopic-continual change. Particles are reacting in a forward direction and in a reverse direction

the characteristics of a system in dynamic equilibrium can be described and explained in terms of reaction rates and macroscopic properties

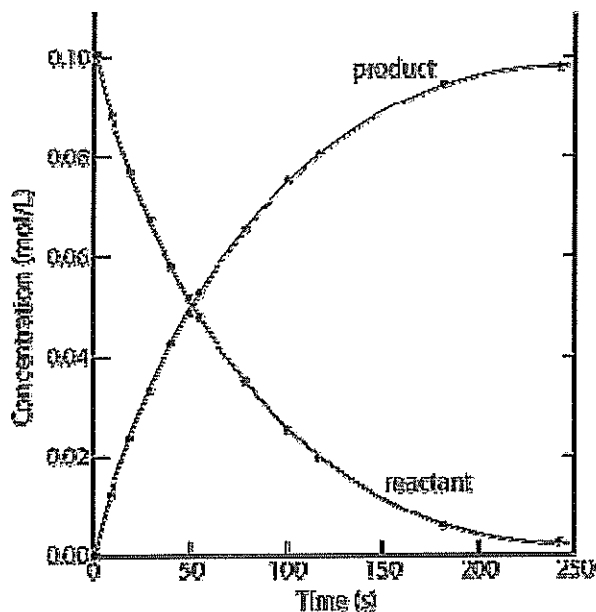

Chemical reactions are reversible,

The questions can be tricky. e.g. With the $\text{NO}_2 / \text{N}_2\text{O}_4$ situation where a syringe of NO_2 is squeezed. The gas becomes more brown because it is more concentrated and then less brown as equilibrium is achieved. Use the words MORE and LESS – don't say goes brown and goes colourless.

The normal outcome of all reversible chemical reactions is a state of dynamic equilibrium, when rate of the forward reaction is equal to the rate of the reverse reaction at a given temperature.

When equilibrium is attained the individual species, both reactants and products, present are still reacting even though their individual concentrations remain constant at a specified temperature.

The equilibrium state of a reaction can be approached from either direction.

The equilibrium state may take an infinite time to be attained.

The time to reach equilibrium is the same whether approached from reactants or products.

The equilibrium position may be altered, or shifted, by altering certain factors like temperature, concentration or volume.

A catalyst affects the rate of a chemical reaction but has no effect on the position of equilibrium. It affects how quickly this point is reached.

The bulk of chemical reactions, given the right conditions, will eventually reach a balance between reactant and product and will remain in this balanced state. This is called the equilibrium state.

the reversibility of chemical reactions can be explained in terms of the activation energies of the forward and reverse reactions

the effect of changes of temperature on chemical systems initially at equilibrium can be predicted by considering the enthalpy changes for the forward and reverse reactions; this can be represented on

energy profile diagrams and explained by the changes in the rates of the forward and reverse reactions

- When chemical reactions occur, as well as the formation of the products - the chemical change, there is also a heat energy change which can often be detected as a temperature change.
- This means the products have a different energy content than the original reactants (see the reaction profile diagrams below).
- If the products contain less energy than the reactants, heat is released or given out to the surroundings and the change is called *exothermic*. The temperature of the system will be observed to rise in an exothermic change.
- If the products contain more energy than the reactants, heat is taken in or absorbed from the surroundings and the change is called *endothermic*. If the change can take place spontaneously, the temperature of the reacting system will fall but, as is more likely, the reactants must be heated to speed up the reaction and provide the absorbed heat.
- The difference between the energy levels of the reactants and products gives the overall energy change for the reaction
- The heat change is called the enthalpy change is denoted by ΔH .
- ΔH is negative (-ve) for exothermic reactions i.e. heat energy is given out and lost from the system to the surroundings which warm up.
- ΔH is positive (+ve) for endothermic reactions i.e. heat energy is gained by the system and taken in from the surroundings which cool down OR, as is more likely, the system is heated to provide the energy needed to effect the change.

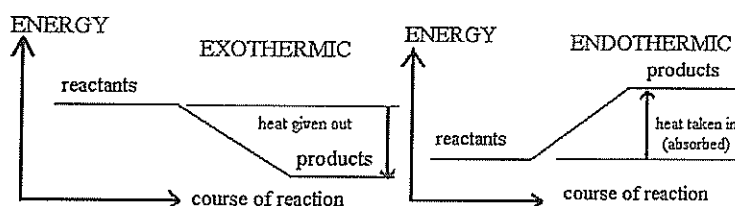

Heat Changes in Physical Changes of State

- Changes of physical state i.e. gas \rightleftharpoons liquid \rightleftharpoons solid are also accompanied by energy changes.
- To melt a solid, or boil/evaporate a liquid, heat energy must be absorbed or taken in from the surroundings, so these are endothermic energy changes (ΔH +ve). The system is heated.
- To condense a gas, or freeze a solid, heat energy must be removed or given out to the surroundings, so these are exothermic energy changes (ΔH -ve). The system is cooled to effect these changes.
- The stronger the forces between the individual molecules, atoms or ions, the more energy is needed to melt or boil the substance.
- As this is shown by the varying energy requirements to melt or boil a substance.

Reversible Reactions and Energy Changes

- If the direction of a reversible reaction is changed, the energy change is also reversed.

The Significance of activation energy

When gases or liquids are heated the particles gain kinetic energy and move faster increasing the chance of collision between reactant molecules and therefore the increased chance of a fruitful collision (i.e. one resulting in product formation).

- However this is NOT the main reason for the increased reaction speed on increasing the temperature of reactant molecules because most molecular collisions do not result in chemical change.
- Before any change takes place on collision, the colliding molecules must have a minimum kinetic energy called the activation energy.
- Do not confuse activation energy with the overall energy change also shown in the diagrams below, that is the overall energy absorbed-taken in by the system (endothermic) or given out to the surroundings (exothermic).
- It does not matter whether the reaction is an exothermic or an endothermic energy change, Higher temperature molecules in gases and liquids have a greater average kinetic energy and so a greater proportion of them will then have the required activation energy to react on collision.

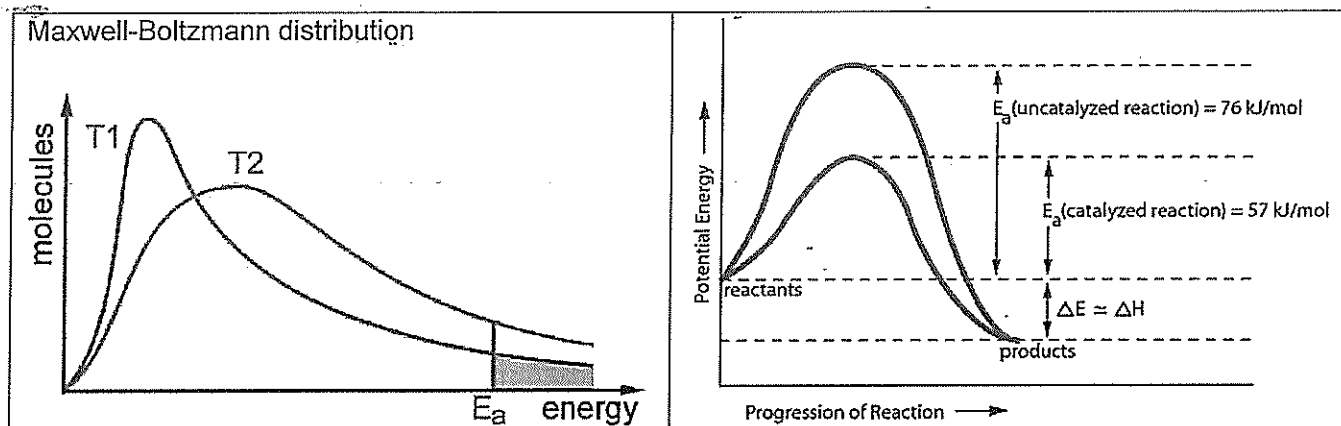

- The increased chance of higher energy collisions greatly increases the speed of the reaction because it greatly increases the chance of a fruitful collision forming the reaction products by bonds being broken in the reactants and new bonds formed in the reaction products.
- The activation energy 'hump' can be related to the process of bond breaking and making.
 - Up the hump is endothermic, representing breaking bonds (energy absorbed, needed to pull molecules apart),
 - down the other side of the hump is exothermic, representing bond formation (energy released, as atoms become electronically more stable).
 - *In an exothermic reaction if the temperature is raised then more particles can achieve the large reverse E_a and the position of equilibrium will shift backwards as predicted by Le Châtelier's Principle.*

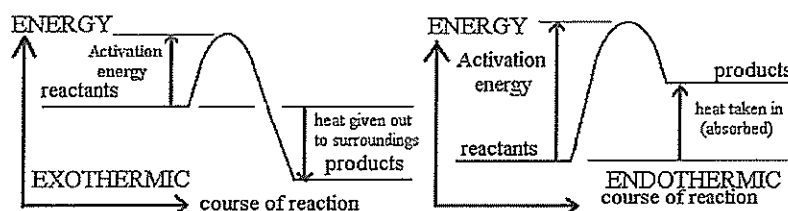

the effects of changes in concentration of solutions and partial pressures of gases on chemical systems initially at equilibrium can be predicted and explained by applying collision theory to the forward and reverse reactions

you must not talk about LCP or hint at it if you are asked to "explain" or if you are asked to discuss collisions.

e.g. – increasing reactant concentration: You must say increasing a reactant concentration increases the number of collisions and so increases the forward rate of reaction. The reverse rate is unchanged so the equilibrium moves to the right.

changes in partial pressures of gases – see above re concentration

addition of a catalyst

catalysts offer a new pathway with lower E_a for both forward and reverse reactions. They increase rate forward and backwards **AND do not say "they lower the E_a "**

the effects of changes in temperature, concentration of species in solution, partial pressures of gases, total volume and the addition of a catalyst on equilibrium systems can be predicted using Le Châtelier's Principle

To get the maximum amount of useful products from reactions is the aim of industry.

Henry le Châtelier observed how concentration changes, pressure changes and heat changes altered the position of equilibrium. Thus, equilibrium can be upset by altering the conditions, and the system will tend to respond by trying to offset these changes. => *if the conditions of equilibrium are changed, then the system will respond in such a way as to counteract the introduced changes.* ∴ the K_c must remain the same always for a given temperature..

equilibrium law expressions can be written for homogeneous and heterogeneous systems; the equilibrium constant (K), at any given temperature, indicates the relationship between product and reactant concentrations at equilibrium

Law of Chemical Equilibrium

When the situation of chemical equilibrium is reached, the rates of both the forward and the reverse reaction are equal.

- the concentrations of the reactants and products now present are constant, at constant temperature

K_c is called the equilibrium constant – can only be calculated when the system is at equilibrium

$$K_c = \frac{[\text{Products}]}{[\text{Reactants}]}$$

K_c is written as the concentration of products (use square brackets) over the concentration of the reactants present in the solution at equilibrium and a stated temperature.

Equilibrium Law -

"In a chemical system at equilibrium, the ratio of the product of the molar concentrations of the products divided by the products of the molar concentrations of the reactants, each raised to the coefficient given in the equation used to describe this equilibrium, has a constant value at a given temperature."

It is important to note that if a reactant or a product in a chemical reaction is in either the liquid or solid phase, the "concentration" is meaningless. Therefore, these terms can be left out of the equation to calculate K_c .

Homogeneous and heterogeneous Equilibria

We need to look at two different types of equilibria (homogeneous and heterogeneous) separately, because the equilibrium constants are defined differently.

- A **homogeneous equilibrium** has everything present in the same phase. The usual examples include reactions where everything is a gas, or everything is present in the same solution.
- A **heterogeneous equilibrium** has things present in more than one phase. The usual examples include reactions involving solids and gases, or solids and liquids.

K_c in homogeneous equilibria

This is the more straightforward case. It applies where everything in the equilibrium mixture is present as a gas, or everything is present in the same solution.

A good example of a gaseous homogeneous equilibrium is the conversion of sulfur dioxide to sulfur trioxide at the heart of the Contact Process:

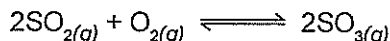

A commonly used liquid example is the esterification reaction between an organic acid and an alcohol - for example:

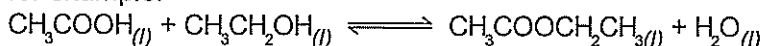

Writing an expression for K_c

We are going to look at a general case with the equation:

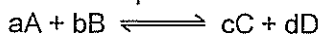

No state symbols have been given, but they will be all (g), or all (l), or all (aq) if the reaction was between substances in solution in water.

If you allow this reaction to reach equilibrium and then measure the equilibrium concentrations of everything, you can combine these concentrations into an expression known as an **equilibrium constant**.

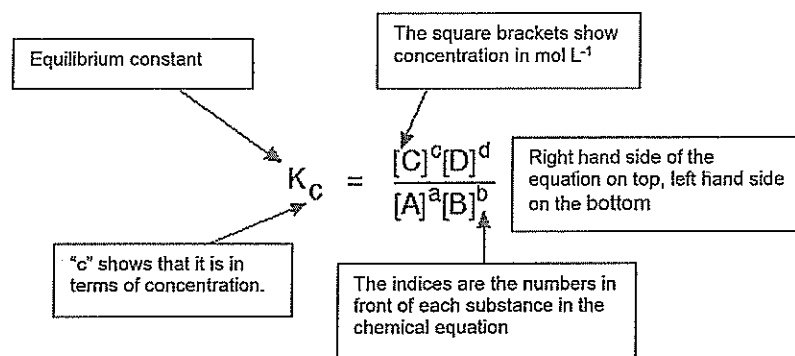

The equilibrium constant always has the same value (provided you don't change the temperature), irrespective of the amounts of A, B, C and D you started with. It is also unaffected by a change in pressure or whether or not you are using a catalyst.

Compare this with the chemical equation for the equilibrium. The convention is that the substances on the right-hand side of the equation [products] are written at the top of the K_c expression, and those on the left-hand side [reactants] at the bottom.

The indices (the powers that you have to raise the concentrations to - for example, squared or cubed or whatever) are just the numbers that appear in the equation.

the relative amounts of reactants and products (equilibrium position) can be predicted qualitatively using equilibrium constants (K_c)

In this course there is to be no calculating of K_c

Magnitude of Equilibrium Constants

- K_c is a measure of ;
 - - how far a reaction will go under a certain set of conditions, temperature being the most important of these.
 - - yield (final product concentrations compared to initial reactant concentrations.)
- The larger the value for the equilibrium constant the more the reaction goes to completion. Irreversible reactions can be thought to have an infinite equilibrium constant so there are no reactants left.

What does an equilibrium constant tell us ?

- The number values for equilibrium constants are tied to the nature of reactants and products in a reaction. The number values for "K" are found from experiments measuring equilibrium concentrations. The number value tells the equilibrium ratio of products to reactants. In an equilibrium mixture both reactants and products coexist.
- Large $K > 1$ products are "favoured"
- $K = 1$ neither reactants nor products are favoured
- Small $K < 1$ reactants are "favoured"
- Large K may have values that are huge, 1×10^{34}
- Small K may have values that are tiny, 4×10^{-58}

	Rate of reaction	Shifting position of equilibrium	Equilibrium constant - K_c
Increase of pressure	Increases	Changed only if diff # mol on lhs & rhs	Unchanged
Decrease of pressure	Decreases	Changed only if diff # mol on lhs & rhs	Unchanged
Increase of reactant concentration	Increases product	Increases	Unchanged
Decrease of reactant concentration	Decreases product	Decreases	Unchanged
Catalyst added	Changed	Unchanged	Unchanged
Temperature increase	Increase	Changed - dep on enthalpy change	Changed dep on enthalpy change.
Decrease temperature	Decrease	Changed - dep on enthalpy change	Changed dep on enthalpy change

Science as a Human Endeavour

Levels of carbon dioxide in the atmosphere are rising and have a significant impact on global systems, including surface temperatures. The increasing level of carbon dioxide in the atmosphere causes more carbon dioxide to dissolve in the ocean producing carbonic acid and leading to increased ocean acidity. This is predicted to have a range of negative consequences for marine ecosystems such as coral reefs. Calcification is the process which results in the formation of calcium carbonate structures in marine organisms. Acidification shifts the equilibrium of carbonate chemistry in seawater, decreasing the rate and amount of calcification among a wide range of marine organisms. The United Nations Kyoto Protocol and the Intergovernmental Panel on Climate Change aim to secure a global commitment to reducing greenhouse gas emissions over the next few decades.

Ocean Acidification : A complex Buffer

Due to **Greenhouse Gas emission**, the levels of CO₂, in our oceans is steadily rising.

Atmospheric carbon dioxide is in equilibrium with dissolved carbon dioxide in the ocean (see equation 1).

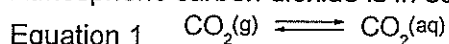

The dissolved carbon dioxide undergoes hydrolysis (equation 2).

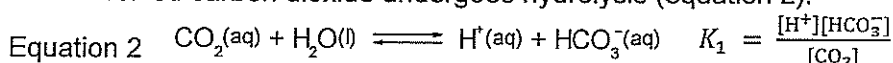

As the concentration of dissolved CO₂ increases the pH of the ocean falls, becoming more acidic. Average global surface ocean pH has already fallen from a pre-industrial value of 8.21 to 8.10, corresponding to an increase in acidity of 28.8%. By 2100, pH values of 7.8-7.9 are expected, representing a 100–150% increase in acidity.

Calcium carbonate does dissolve at the rate of 0.13 g/L and the ocean is a saturated solution of calcium carbonate (equation 3) and it is this source of carbonate ions that corals and shellfish use to create their exoskeleton.

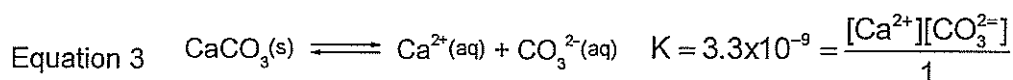

The excess H⁺ formed as the ocean becomes more acidic (Equation 2) reacts with soluble carbonate in the ocean (equation 3) resulting in an increase in the concentration of HCO₃⁻ (equation 4).

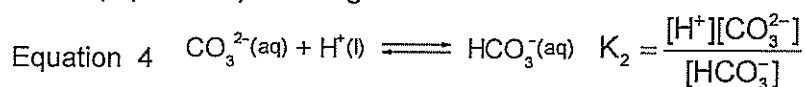

Coral body is built from calcium carbonate when the carbonate ions combine with calcium ions in the water.

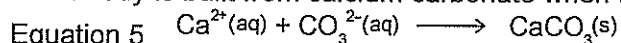

In accordance with Le Châtelier's Principle as the hydrogen ion removes carbonate ion in Equation 4 it will force Equation 3 to the right to replace some of the carbonate. Not all is replaced because the [Ca²⁺] is rising and to maintain K the carbonate decreases. There is an effective lowering of carbonate ion concentration.

It is predicted that the effect of acidification of the oceans is to remove carbonate ion from the water causing a reduction in the ability of the coral polyp skeleton to form. This ultimately results in stunted growth of corals.

Answering exam questions in terms of le Châtelier's Principle

Be very careful ! Le Chatelier does not explain – he only predicts ! See below.

Question: Predict whether KCl will be precipitated from its saturated solution by passing HCl gas through it?

Answer: in a saturated solution of KCl we may assume that the equilibrium

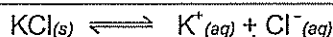

has established itself. Addition of HCl gas will lead to an increase in $[\text{Cl}^-]_{\text{aq}}$ above its equilibrium value and, in accord with Le Châtelier's Principle, the equilibrium will adjust in the direction which tends to offset this increase. Such adjustment can only be made by having $\text{K}^+_{(aq)}$, $\text{Cl}^-_{(aq)}$ ions associate to form $\text{KCl}_{(s)}$.

Question: Explain why KCl can be precipitated from its saturated solution by passing HCl gas through it.

Answer: in a saturated solution of KCl we may assume that the equilibrium

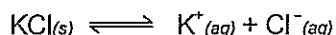

has established itself. Addition of HCl gas will lead to an increase in $[\text{Cl}^-]_{\text{aq}}$ above its equilibrium value.

Thus we have increased the concentration of a species and there is more chance of a collision and the rate of the reverse reaction will increase so the equilibrium will move to the left.

ATAR Chemistry

Unit 3 : Equilibrium and Rate

Twenty Years of TEE Unit 3 Questions 1990 – 2010

1990 Part 1

8 Which one of the following statements about the following reversible reaction is TRUE?

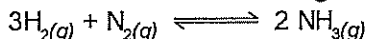

(Equilibrium constant = K. Heat of reaction = ΔH)

(a) $\frac{[\text{NH}_3]^2}{[\text{H}_2]^3[\text{N}_2]} = K$

(b). K is constant under all conditions.

(c) A catalyst increases the yield of ammonia by increasing ΔH .

(d) Ammonia is being formed when the gases are at equilibrium.

(e) Increasing the pressure increases K.

9. For the chemical reaction:

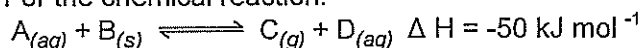

Which one of the following actions would increase the rate of the reaction?

(a) Using the same mass of B, but in larger lumps.

(b) Increasing the pressure inside the reaction vessel.

(c) Heating the reaction mixture.

(d) Increasing the volume of the reaction mixture.

(e) Decreasing $[\text{A}_{(aq)}]$.

1990 Part 2

4. Consider the following system at equilibrium in a closed vessel:

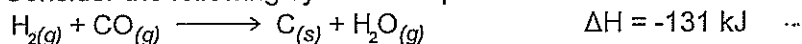

(a) The equilibrium is disturbed by increasing the temperature. After a new equilibrium is established, is the amount of CO more, less or the same as before? *more*

(1 mark)

(b) If the original equilibrium was disturbed by decreasing the volume of the reaction vessel, keeping the temperature constant, would the amount of CO be more, less or the same as before? Explain. *less*

(1 mark)

- (c) If solid carbon were added to the system at equilibrium, would the amount of CO be more, less or the same as before? *SAME*

(1 mark)

1991 Part 1

8. Methanol can be synthesized from carbon monoxide and hydrogen as illustrated by the equation:
 $2\text{H}_2(g) + \text{CO}(g) \rightleftharpoons \text{CH}_3\text{OH}(g) \quad \Delta H = -92 \text{ kJ}$
Which of the following sets of reaction conditions would maximise the yield of methanol at equilibrium?
- (a) High temperature, high pressure.
(b) High temperature, low pressure.
(c) Low temperature, low pressure.
(d) Low temperature, high pressure.
(e) High temperature, high pressure and a catalyst.
14. Hydrogen is commonly prepared in the laboratory by the reaction between zinc granules and dilute hydrochloric acid. The reaction is exothermic. If this reaction is performed, using one mole of zinc and one mole of hydrochloric acid, which one of the following would reduce the rate of production of hydrogen?
- (a) Increasing the temperature.
(b) Increasing the concentration of the hydrochloric acid.
(c) Adding water.
(d) Increasing the amount of zinc present.
(e) Cutting the zinc into smaller pieces.
15. Consider the reaction :
 $2\text{NO}(g) + \text{O}_2(g) \longrightarrow 2\text{NO}_2(g)$
Increasing the pressure of this system causes the rate of the reaction to increase. Which of the following statements best explains this observation?
- (a) The volume of the reactants is greater than that of the products.
(b) The number of reactant molecules with energies greater than the activation energy for the reaction will increase.
(c) The total kinetic energy of the system will increase.
(d) The particles will collide more often.
(e) The average kinetic energy of the reactant molecules will increase.
27. When a student attempts to prepare carbon dioxide by adding marble chips (CaCO_3) to 2 M aqueous sulfuric acid, there is very little sign of gas evolution. Which of the following is the best reason for this observation?
- (a) Calcium carbonate is insoluble in water.
(b) Sulfuric acid is not a very strong acid when diluted.
(c) Carbon dioxide is totally miscible with aqueous sulfuric acid.
(d) Calcium sulfate is insoluble in aqueous sulfuric acid.
(e) The reaction is reversible.

1992 Part 1

29. In an experiment, 2 g of magnesium shavings dissolve in 500 mL of 2 mol L⁻¹ hydrochloric acid with the production of considerable quantities of heat. Which one of the following actions will NOT increase the initial rate of production of hydrogen?
- (a) Using the same mass of magnesium but using larger pieces of the metal.
(b) Heating the reaction mixture.
(c) Using 500 mL of 5 mol L⁻¹ acid instead of 500 mL of 2 mol L⁻¹ acid.
(d) Stirring the reaction mixture.
(e) Using 10 g of the original magnesium shavings instead of 2 g.

1992 Part 3

6. Carbon disulfide can be manufactured by the endothermic reaction of sulfur trioxide and carbon dioxide according to the equation:
 $2\text{SO}_3(\text{g}) + \text{CO}_2(\text{g}) \rightarrow \text{CS}_2(\text{g}) + 4\text{O}_2(\text{g})$
 If this reaction is allowed to come to equilibrium at 100 °C and a pressure of 400 kPa, what would be the effect on the equilibrium amount of carbon disulfide of each of the following changes? (Write "increase", "decrease" or "no change")

a.	Raising the temperature to 200 °C whilst maintaining the pressure at 400 kPa.	increase	✓
b.	Reducing the pressure to 200 kPa whilst maintaining the temperature at 100°C.	decrease	✓ increase
c.	Removing oxygen from the equilibrium mixture.	increase	✓

[6 marks]

1993 Part 1

15. One step in the production of titanium metal from rutile (TiO_2) involves the following reaction at high temperature:



For this reaction $\Delta H = -77 \text{ kJ mol}^{-1}$. Which of the following will increase the rate of reaction?

- I Grinding the TiO_2 and C more intimately together
- II Increasing the temperature
- III Increasing the pressure

- (a) I only
 (b) I and II only
 (c) I and III only
 (d) III only
 (e) All of I, II and III
- 16 For the system $\text{N}_{2(\text{g})} + 3 \text{H}_{2(\text{g})} \rightleftharpoons 2 \text{NH}_{3(\text{g})}$ which one of the following statements about the equilibrium constant K is false?
 (a) At a constant temperature, K is constant over a range of pressures.
 (b) At a constant pressure, K is constant over a range of temperatures.
 (c) The value of K at a constant temperature remains the same when a catalyst is added.
 (d) The smaller the value of K, the larger the value of $\frac{[\text{N}_2][\text{H}_2]}{[\text{NH}_3]^2}$ at equilibrium.
 (e) A large value of K may not mean rapid production of ammonia.

17. The solubility of calcium chromate is 0.9 mol L^{-1} at 25°C. Consider the equilibrium
 $\text{CaCrO}_{4(\text{s})} \rightleftharpoons \text{Ca}^{2+}(\text{aq}) + \text{CrO}_4^{2-}(\text{aq})$
 An equilibrium mixture is prepared consisting of a few yellow crystals of calcium chromate below a yellow solution. What is observed when a little concentrated (5 mol L^{-1}) calcium chloride solution is added to the mixture?
 (a) More yellow crystals form, and the solution becomes paler.
 (b) More yellow crystals form, and the solution becomes a darker yellow.
 (c) The yellow crystals dissolve, and the solution becomes paler.
 (d) The yellow crystals dissolve, and the solution becomes a darker yellow.
 (e) There is no significant change in appearance.

1993 Part 2

3. In the spaces provided, briefly state the chemical reason for each of the following observations.

Statement	Explanation
Although many metal carbonates react with acid, calcium carbonate does not react	

significantly with dilute sulfuric acid.

[4 marks]

11. One step in the Contact Process for the manufacture of sulfuric acid involves the following reaction
- $$2\text{SO}_{2(g)} + \text{O}_{2(g)} \longrightarrow 2\text{SO}_{3(g)} \quad \text{for which } \Delta H = -200 \text{ kJ mol}^{-1}$$

This reaction is allowed to come to equilibrium at 450°C and a pressure of 101 kPa. In the table below describe the effect of each of the described changes in conditions on the equilibrium amount of sulfur trioxide. Write 'increase', 'decrease', or 'no difference', and give a brief reason for your answer.

Change in system	Effect of this change on amount of SO ₃ 'increase', 'decrease' or 'no difference'.	Reason
The temperature is raised to 600°C, whilst the pressure is kept at 101 kPa.	increase / decrease	
The pressure is raised to 1010 kPa by reducing the volume, whilst the temperature is kept at 450°C.	increase	
V ₂ O ₅ catalyst is added to the system, whilst the original temperature and pressure are maintained.	NO CHANGE	✓

1994 Part 1

20. Which one of the following statements is true?
- (a) The rates of all chemical reactions increase with temperature.
 - (b) Exothermic reactions slow down when the reactants are heated.
 - (c) Only endothermic reactions go faster when the reactants are heated.
 - (d) Heating the reactants in an exothermic reaction causes the system to attain a state of equilibrium.
 - (e) Only exothermic reactions proceed spontaneously at room temperature.

INFORMATION FOR QUESTIONS 21 AND 22

The following two questions are about a step in the production of nickel at the Kwinana Nickel Refinery. The ore is originally treated with ammonia and oxygen, converting the nickel into tetraamminenickel (II) ion. In the next step, considered here, this complex ion is treated with hydrogen gas and converted to nickel metal. The forward reaction is represented by the following equation.

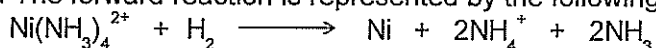

21. Which of the following sets of conditions will bring about the highest yield of nickel at equilibrium?
- (a) High partial pressure of hydrogen and low partial pressure of ammonia
 - (b) High partial pressure of hydrogen and high partial pressure of ammonia
 - (c) Low partial pressure of hydrogen and low partial pressure of ammonia
 - (d) Low partial pressure of hydrogen and high partial pressure of ammonia
 - (e) High partial pressure of hydrogen and low partial pressure of air
22. Which of the following conditions will bring about the fastest rate of formation of nickel?
- (a) High partial pressure of hydrogen
 - (b) Low partial pressure of hydrogen
 - (c) High partial pressure of ammonia
 - (d) Low partial pressure of ammonia
 - (e) None of the above, because although equilibrium is affected by gas pressure, rate of reaction is not.
23. As ammonium chloride dissolves in water the temperature of the solution decreases. Which one of the following statements about the reaction is false?
- (a) ΔH for $\text{NH}_4\text{Cl}_{(s)} \longrightarrow \text{NH}_4^+_{(aq)} + \text{Cl}^-_{(aq)}$ is negative.

- (b) When the NH_4Cl dissolves, the NH_4^+ reacts to a small extent with water to give an acidic solution.
- (c) When the NH_4Cl dissolves, the conductivity of the solution increases.
- (d) NH_4Cl dissolves more rapidly as the temperature is raised.
- (e) More energy is needed to separate the ions from each other than is released when water molecules surround the ions.

24. Consider the reversible reaction

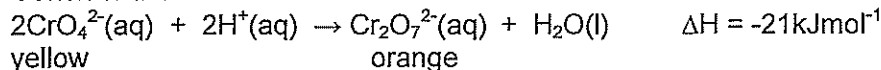

An equilibrium mixture is prepared, yellow-orange in colour, containing both sodium chromate and sodium dichromate in solution. Which one of the following statements is false?

- (a) When sodium hydroxide solution is added, the mixture becomes both less orange and more yellow.
- (b) When dilute hydrochloric acid is added, the mixture becomes both less yellow and more orange.
- (c) When a few crystals of sodium chromate are added and dissolved, the mixture becomes both more orange and more yellow.
- (d) When a little barium chloride solution is added so that insoluble barium chromate precipitates, the solution becomes both less orange and less yellow.
- (e) When the temperature is increased, the value of the equilibrium constant does not change.

1995 Part 2

11. Hydrogen sulfide, when bubbled through water, gives rise to a very low concentration of sulfide ion as a result of three equilibria:

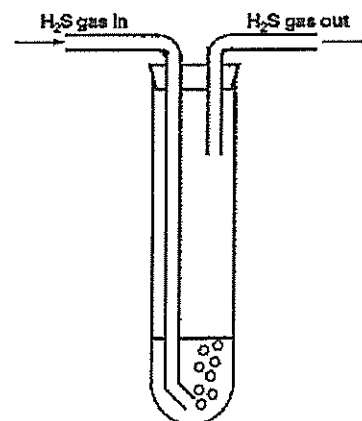
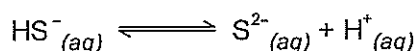
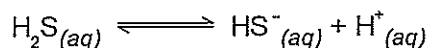
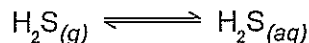

Five identical sets of apparatus are set up as illustrated, with hydrogen sulfide gas bubbled through water continuously.

Each apparatus is treated as described below: predict the effect on the sulfide ion concentration in the water.

Experiment	Effect on $[\text{S}^{2-}]$. Write 'increase', 'decrease' or 'no change'
One drop of concentrated hydrochloric acid is added to the water	NO CHANGE
One sodium hydroxide pellet is dissolved in the water	INCREASE
One drop of concentrated ammonia solution is added to the water	INCREASE
A few crystals of ammonium chloride are dissolved in the water	DECREASE
The gas escape tube is blocked so that the gas pressure increases	INCREASE

[5 marks]

13. Write the equation for the industrial synthesis of ammonia. This reaction takes place exceedingly slowly at room temperature and pressure. List three ways in which chemists control reaction conditions to speed up the process. [4 marks]

1996 Part 2

11. When cobalt chloride is dissolved in dilute hydrochloric acid the following equilibrium is set up.



Both the red ion and the deep blue ion are present in the reaction mixture which is therefore purple. Three test-tubes are set up, each containing some of the equilibrium mixture. Each of the tubes is treated as described below. In each case state how the equilibrium will shift, and what will be observed.

What is done	How the equilibrium shifts. Write ← or → or 'no change'	What is observed. Give the complete observation	Explain the observation
A little concentrated hydrochloric acid is added to the first tube	→	BECOMES MORE BLUE	
A little silver nitrate solution is added to the second tube	←	BECOMES MORE RED AgCl IS INSOLUBLE, FORMS WHITE PRECIPITATE	
A little concentrated cobalt nitrate solution is added to the third tube	→	BECOMES MORE BLUE AND MORE RED	

[8 marks]

12. Explain the following.

	Explanation
Finely-chopped pieces of wood ignite faster than large lumps of wood.	MORE SURFACE AREA, THEREFORE MORE COLLISIONS OCCUR, THEREFORE THERE ARE MORE SUCCESSFUL COLLISIONS.
Nitrogen reacts faster with hydrogen when a high pressure is used.	WITH A HIGHER PRESSURE, COLLISIONS ARE MORE LIKELY TO TAKE PLACE AND THE MOLECULES ARE MORE LIKELY TO FORM.
Sulfur dioxide reacts faster with oxygen when a suitable catalyst is used.	THE CATALYST PROVIDES A FASTER REACTION PATH SO THAT THE REACTION OCCURS MORE QUICKLY THAN BEFORE.

1997 Part 1

12. Which of the following best describes a condition which is necessary for the following reaction to be at equilibrium?



- (a) All species are present in equal concentrations.
 (b) The concentrations of $\text{CH}_4(g)$, $\text{H}_2\text{O}(g)$ and $\text{CO}(g)$ are equal.
 (c) The pressure in the reaction vessel remains constant.
 (d) The ratio of $\frac{[\text{CO}][\text{H}_2]^3}{[\text{CH}_4][\text{H}_2\text{O}]}$ is equal to 1.
 (e) The sum of the concentrations of all species is constant.

✓
ALSO C

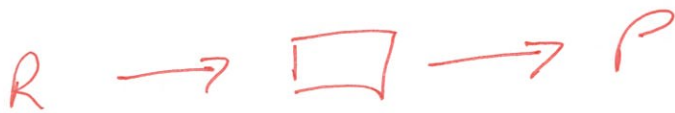

13 In the laboratory under the heading 'Effect of catalysts on reaction rate' you may have carried out the following experiment.

- Some hydrogen peroxide solution is added to sodium potassium tartrate solution: there is no evidence of reaction.
- The mixture is then heated to 65°C: there is still no evidence of reaction.
- A few drops of cobalt chloride solution are then added: the red colour of the cobalt changes to blue; the reaction mixture bubbles violently and the temperature rises rapidly; and after a few seconds the bubbles stop forming and the red colour returns.

The overall reaction is



Which one of the following reaction profiles is consistent with the experiment?

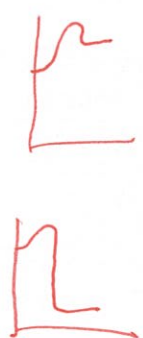
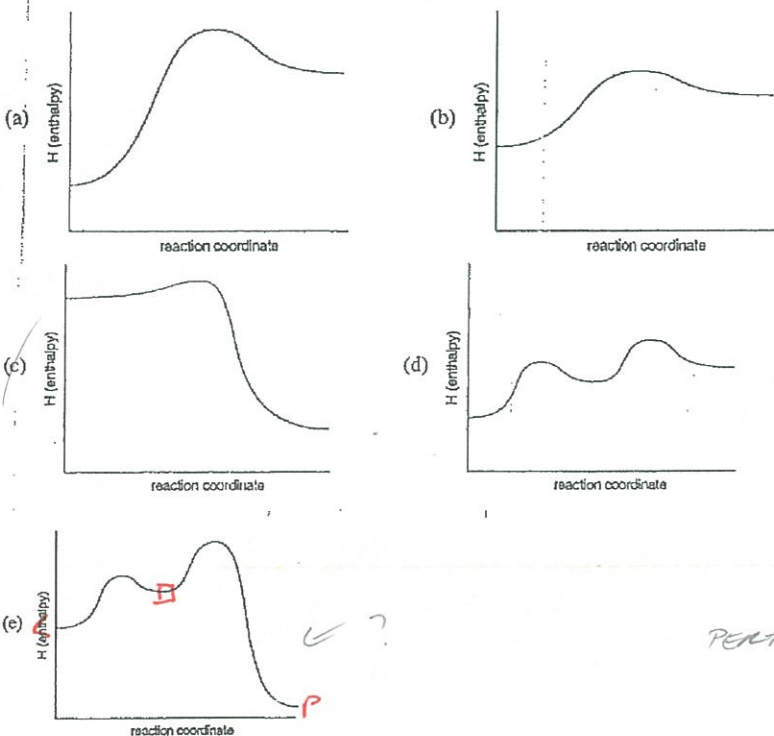

PENTACHEMIST@GMAIL.COM

1997 Part 2

12. The Ostwald Process is the most widely used method for making nitric acid. In one step of the process ammonia is burnt in air at 900°C, at atmospheric pressure, and in the presence of a platinum/rhodium catalyst. The equation for the reaction is

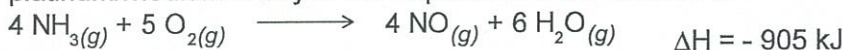

The system finally comes to equilibrium. Explain how each of the following factors affects both the rate of formation of nitrogen oxide and the yield of nitrogen oxide.

	Explanation (in terms of both rate and yield)
Why is a temperature of 900°C used rather than room temperature?	
Why is a pressure of 1 atmosphere used rather than a higher or a lower pressure?	
Why is a catalyst used?	

13. Calcium hydroxide is slightly soluble in water. The equilibrium established when solid Ca(OH)₂ is in contact with saturated solution is represented by

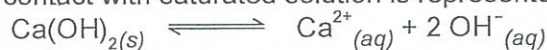

An equilibrium mixture of solid calcium hydroxide and its saturated solution is prepared. Four test-tubes are set up, each containing some of the equilibrium mixture – a little white solid under a colourless solution. Each of the tubes is treated as described below. In each case state how the equilibrium will shift, and what will be observed

What is done	How the equilibrium shifts. Write → ← or "no change"	What is observed. Give the complete observation
A little concentrated hydrochloric acid is added to the first tube.		
A little concentrated (3 mol L ⁻¹) calcium chloride solution is added to the second tube		
A little solid calcium hydroxide is added to the third tube and the mixture shaken.		
A little solid sodium chloride is added to the fourth tube and the mixture shaken.		

1998 Part 1

[8 marks]

14. Consider the following system at equilibrium.



Colourless Pale yellow green red

- External pressure is applied to halve the volume. Which one of the following occurs?
- The equilibrium shifts to the right, and the final colour is darker than the original.
 - The equilibrium shifts to the right, and the final colour is paler than the original.
 - The equilibrium shifts to the left, and the final colour is darker than the original.
 - The equilibrium shifts to the left, and the final colour is paler than the original.
 - There is no shift in equilibrium, and the final colour is darker than the original.

- 30 The commercial production of ammonia using the Haber Process involves an exothermic reaction between nitrogen gas and hydrogen gas. Which one of the following statements is true?
- Continual removal of the ammonia formed will increase the rate at which the hydrogen gas and nitrogen gas react.
 - High temperature and high pressure each increase the rate of formation of ammonia.
 - Removal of the catalyst will affect both forward and reverse reactions and thus make no appreciable difference to the rate of production of ammonia.
 - The rate of production of ammonia will be greater at low temperature than at high temperature.
 - The rate of production of ammonia will be lower at high pressure than at low pressure.

1999 Part 1

11. A small increase in temperature can produce a relatively large increase in the rate of a chemical reaction. Which one of the following statements best explains this?
- At a higher temperature there is a large increase in the proportion of reactant particles with sufficient energy to form the activated complex.
 - The activation energy for a reaction gets lower as the temperature gets higher.
 - The extra energy orients the molecules for a reaction.
 - The increase in temperature strengthens the bonds in the products so that it is easier for the new compound to form.

13. The reaction of coal with steam in a vessel at constant volume produces a mixture of hydrogen and carbon monoxide gases.

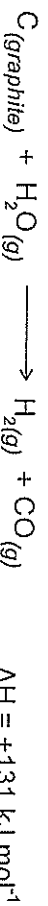

- Which one of the following changes would slow down the rate of reaction?
- decreasing the pressure of the steam

- (b) grinding up the coal
- (c) injecting CO gas into the reaction vessel
- (d) raising the temperature of the steam

14. Ethyne can be converted into ethanal according to the following equation:

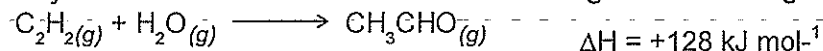

Which one of the following changes would increase the yield of ethanal?

- (a) adding a catalyst
- (b) increasing the pressure of the steam
- (c) increasing the volume
- (d) lowering the temperature

1999 Part 2

5. Distilled water, which has been exposed to air, has a pH of about 5. When it is boiled and then cooled, the pH has changed to 7. The pH of the distilled water prepared in this way then slowly falls back to about 5. Explain with the aid of equations the role of carbon dioxide in these observations.

3 marks

2000 Part 1

17. Which of the following best explains the way in which a catalyst increases the rate of a reaction?
- (a) A catalyst increases the rate of the forward reaction but not the reverse reaction: hence the overall rate is increased.
 - (b) A catalyst provides additional energy to the particles: hence a greater fraction of collisions is effective.
 - (c) A catalyst provides an alternative reaction pathway with a lower activation energy: hence a greater fraction of collisions is effective.
 - (d) A catalyst provides an alternative reaction pathway with a lower heat of reaction: hence less energy is needed for the particles to react.
18. Consider the following endothermic reaction for the production of hydrogen gas in a rigid container:
 $\text{CH}_4(\text{g}) + \text{H}_2\text{O}(\text{g}) \rightarrow \text{CO}(\text{g}) + 3\text{H}_2(\text{g})$ Which of the following would increase the final yield of hydrogen gas?
- a) adding a catalyst
 - b) adding inert argon gas
 - c) increasing the pressure
 - d) increasing the temperature

Use the following information to answer Questions 19 to 21 which concern the reaction:

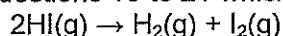

In the absence of a catalyst, the activation energy for the forward reaction is 183 kJ mol^{-1} and the activation energy for the reverse reaction is 157 kJ mol^{-1} . In the presence of a platinum catalyst the activation energy for the forward reaction is 58 kJ mol^{-1} .

19. What is ΔH for the reaction $2\text{HI}(\text{g}) \rightarrow \text{H}_2(\text{g}) + \text{I}_2(\text{g})$ in the absence of a catalyst?
- a) 26 kJ mol^{-1}
 - b) $+ 26 \text{ kJ mol}^{-1}$
 - c) 84 kJ mol^{-1}
 - d) $+ 84 \text{ kJ mol}^{-1}$
20. What is ΔH for the reaction $2\text{HI}(\text{g}) \rightarrow \text{H}_2(\text{g}) + \text{I}_2(\text{g})$ in the presence of a platinum catalyst?
- a) 26 kJ mol^{-1}
 - b) $+ 26 \text{ kJ mol}^{-1}$
 - c) 84 kJ mol^{-1}
 - d) $+ 84 \text{ kJ mol}^{-1}$
21. Which one of the following statements about the reaction $\text{H}_2(\text{g}) + \text{I}_2(\text{g}) \rightarrow 2\text{HI}(\text{g})$ in the presence of a platinum catalyst is true?
- a) The activation energy is 32 kJ mol^{-1} .
 - b) The activation energy is 99 kJ mol^{-1} .
 - c) The activation energy is 157 kJ mol^{-1} .

d) The activation energy cannot be known without further experiment.

22. Which one of the following statements about the value of an equilibrium constant is false?
- It indicates how quickly the reaction is likely to proceed.
 - It indicates the relative proportions of products to reactants at equilibrium.
 - The value is dependent on the temperature.
 - The value is independent of any catalysts present.

2000 Part 2

7. At 95°C pure water has $K_w = 4.8 \times 10^{-13}$. This corresponds to a pH of 6.2. Explain why the pH of pure water at 95 °C is not equal to 7.0.
Is water at 95°C acidic, or is it neutral? Explain your answer.

[4 marks]

8. The following equilibrium is being investigated:

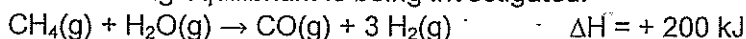

Four identical sealed boxes are set up at 300°C and 101.3 kPa, each containing the equilibrium mixture. Each of the boxes is treated as described below, and time allowed for a new equilibrium to be established. In each case describe the change between the original equilibrium and the new equilibrium.

	What happens to the total pressure? Write 'increase', 'decrease' or 'no change'.	What happens to the partial pressure of CO? Write 'increase', 'decrease' or 'no change'.	What happens to the equilibrium position? Write 'move to the right', 'move to the left' or 'no change'.
The system is heated above 300°C.			
More CH ₄ (g) (at 300°C) is injected into the box.			
Ne(g) (at 300°C) is injected into the box.			
The volume of the box is halved.			

9. Write the equilibrium constant expression for each of the following:

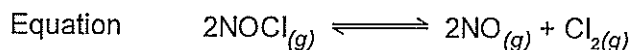
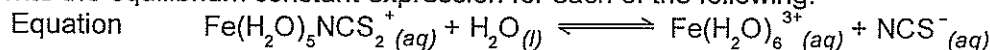

2001 Part 2

7. Write the equilibrium constant expression for each of the following:

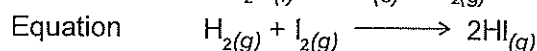
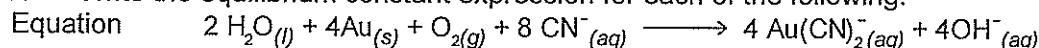

2002 Part 1

4. Which one of the following will change the value of the equilibrium constant (K) for a reaction?
- Increasing the pressure
 - Increasing the state of subdivision of the reactants
 - Increasing the temperature
 - Nothing, since it is a constant

5. The solvent acetone (propanone) can be made by heating 2-propanol with a copper catalyst. The reaction, which is endothermic, is represented by the following equation.

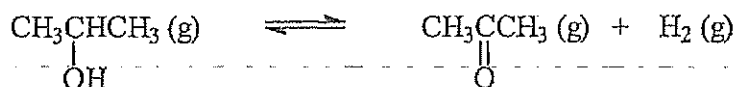

What happens if the temperature of the system is increased from 300°C to 400°C?

- (a) The yield of acetone increases.
 (b) The yield of hydrogen decreases.
 (c) The yield of acetone is unchanged because the forward and reverse reactions are both accelerated.
 (d) The yield of acetone decreases.
30. If a solution contains $1.35 \times 10^{-3} \text{ mol L}^{-1}$ of NaCl what is the concentration in ppm of Na^+ ? (Assume the density of the solution is 1.00 g mL^{-1} .)
- (a) 1350 ppm
 (b) 78.9 ppm
 (c) 47.9 ppm
 (d) 31.0 ppm

2002 Part 2

- 10 The following equilibrium is being investigated:

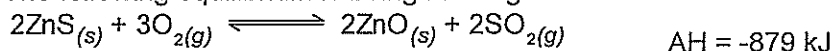

Three identical sealed boxes are set up, each containing the equilibrium mixture. Each of the boxes is treated as described below, and time is allowed for a new equilibrium to be established. In each case describe the change between the original equilibrium and the new equilibrium.

Treatment	What happens to the rate of the forward reaction? Write 'increases', 'decreases' or 'no change'.	What happens to the equilibrium position? Write 'move to the right', 'move to the left' or 'no change'.
A small amount of $\text{O}_{2(g)}$ is added.		
$\text{Ne}_{(g)}$ is pumped in, increasing the pressure of the system (no volume change).		
The reaction vessel is heated.		

2003 Part 1

14. For an exothermic reaction, which one of the following statements is true?
- a) The potential energy of the products is greater than that of the reactants.
 b) The reverse reaction has a higher activation energy than the forward reaction.
 c) The reverse reaction is also exothermic.
 d) The transition state for the reverse reaction has higher potential energy than that for the forward reaction.

Questions 16, 17 and 18 are about the following reaction:

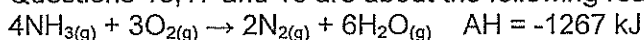

Three changes can be made to the reaction:

- i adding a catalyst
 ii heating the mixture
 iii increasing the pressure

16. Which of the changes will increase the yield of the forward reaction?
- I only
 - II only
 - m only
 - none of the above
17. Which of the changes will increase the rate of the forward reaction?
- I only
 - I and II only
 - I and III only
 - I, II, and III
18. Which one of the options represents the equilibrium constant for the reaction?

$$(a) \quad K = \frac{[N_2]^2 [H_2O]^6}{[NH_3]^4 [O_2]^3} \qquad (b) \quad K = \frac{[NH_3]^4 [O_2]^3}{[N_2]^2 [H_2O]^6}$$

$$(c) \quad K = \frac{[NH_3]^4 + [O_2]^3}{[N_2]^2 + [H_2O]^6} \qquad (d) \quad K = \frac{[N_2]^2}{[NH_3]^4 [O_2]^3}$$

19. A saturated solution of $PbCl_2$ is in contact with excess undissolved solid.

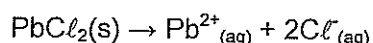

A small quantity of $KCl_{(s)}$ is stirred into the solution. What would happen to the mixture?

- The concentration of $Cl^{-}_{(aq)}$ increases.
- The concentration of $Pb^{2+}_{(aq)}$ decreases.
- The mass of $PbCl_{2(s)}$ increases.
- The $KCl_{(s)}$ will not dissolve in this solution.

- I only
- IV only
- I and II only
- I, II and III only.

2004 Part 1

7. 100 g of mineral water was found to contain 0.00584 g of $NaCl$. What is the concentration of $NaCl$ in parts per million by mass?
- 1.00
 - 5.84
 - 58.4
 - 584
29. Which one of the following is the equilibrium constant expression for this reaction?
- $K = [CO_2]$
 - $K = \frac{[CaO][CO_2]}{[CaCO_3]}$
 - $K = \frac{[CaO] + [CO_2]}{[CaCO_3]}$
 - $K = \frac{1}{[CO_2]}$
30. Consider a sealed system in which $CaCO_3$, CaO and CO_2 are at equilibrium. Now consider the following actions:
- Add more $CO_{2(g)}$ to the system.

- II. Add more $\text{CaCO}_3(\text{s})$ to the system.
- III. Decrease the volume of the system.
- IV. Increase the temperature of the system.

One or more of these actions lead to a change in $\text{CO}_2(\text{g})$ concentration (after equilibrium is re-established). Which statement below is true?

- a) All actions lead to a change in $\text{CO}_2(\text{g})$ concentration.
- b) Only II, III and IV lead to a change in $\text{CO}_2(\text{g})$ concentration.
- c) Only III and IV lead to a change in $\text{CO}_2(\text{g})$ concentration.
- d) Only IV leads to a change in $\text{CO}_2(\text{g})$ concentration.

2004 Part 2

5. (a) A small increase in the temperature of a reaction will often cause a significant increase in the rate of a reaction. Explain, with reference to collision theory, why this is so. Use diagrams if appropriate.

[4 marks]

(b) Draw a potential energy diagram for a reaction with activation energy = 50 kJ mol^{-1} and $\Delta H = +20 \text{ kJ mol}^{-1}$. Label the diagram and axes well, showing the transition state, product and reactants, along with the activation energy and ΔH .

4 marks]

7. Consider 500 mL of a solution in a 1.00 L beaker at 25°C and 101.3 kPa. The solution contains the following equilibrium mixture:



Write 'increase', 'decrease' or 'no change' in the table to indicate the effect of the given changes on the rate of reaction and the equilibrium yield.

Imposed change	Effect on Rate	Effect on Yield
Increase the temperature to 45°C		
Increase the pressure to 200 kPa		
Dissolve some NaCl in the solution		
Divide the solution into ten 50 mL portions in ten 100 mL beakers, to increase the state of subdivision		

8 marks

2005 Part 1

23. When silver sulfide is added to water, the following equilibrium is established.

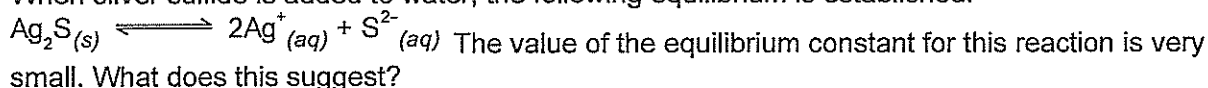

- (a) Adding more silver sulfide will increase the amount of ions in solution.
- (b) Silver sulfide reacts extensively with water.
- (c) Silver sulfide has a very low solubility.
- (d) This reaction is endothermic.

24. When CoCl_2 is dissolved in dilute hydrochloric acid, the following equilibrium is established.

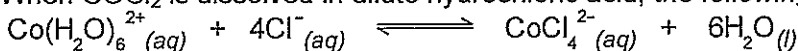

red

deep blue

The solution appears purple in colour as a result of the mixture of the blue and red colours. Which one of the following changes will cause the solution to become more blue in colour?

- (a) A catalyst is added.
- (b) A few drops of concentrated HCl is added.
- (c) A few millilitres of AgNO_3 solution is added.
- (d) The solution is diluted by the addition of water.

25. If solid calcium carbonate is heated in a sealed container, the following equilibrium is established.

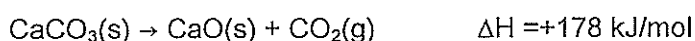

For this system, which one of the following statements about the equilibrium constant K is correct?

- (a) K will increase if the pressure of the system is decreased.
- (b) K will decrease if the partial pressure of the CO_2 is reduced.
- (c) K will increase if the temperature of the system is increased.
- (d) K will remain constant, regardless of any changes made to the system.

29. In a sample of ground water, iron in the form of Fe^{2+} was found to have a concentration of $9.00 \times 10^{-3} \text{ mol L}^{-1}$. Assuming the density of the water sample is 1.00 g mL^{-1} , what is the concentration of Fe^{2+} expressed in ppm?

- (a) 0.502 ppm
- (b) 9.00 ppm
- (c) 50.2 ppm
- (d) 502 ppm

2005 Part 2

7. The reaction between carbon and hydrogen gas to form methane can be represented by the following equation.

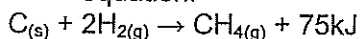

The concentrations of hydrogen and methane were plotted over time and the following graph produced.

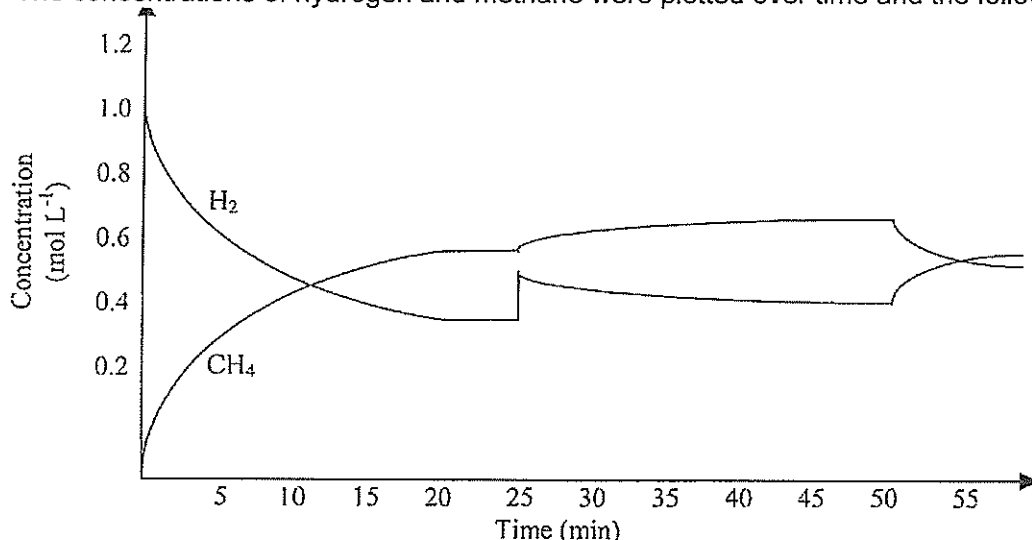

- (a) About what time was equilibrium first established? [1 mark]
- (b) Suggest what could have caused the change at the 25 minute mark. [1 mark]
- (c) Suggest what change to the system occurred at the 50 minute mark. [1 mark]
- (d) What would be the effect on the equilibrium if more $\text{C}(s)$ was added to the system? [1 mark]
- (e) Predict, using Le Châtelier's Principle, what would be the effect of halving the volume of the reaction container. [2 marks]

The Equilibrium Answers

1990 Part 1 Answers

8 (d) 9. (c)

1990 Part 2 Answers

4a more 4b less 4c no change

1991 Part 1 Answers

8. d 14. C 15. d 27. d

1998 Part 1 Answers

14 a 30 b

1999 Part 1 Answers

11 a 13 a 14 b

1999 Part 2 Answers

5. $\text{CO}_{2(g)} + \text{H}_2\text{O}_{(l)} \longrightarrow \text{H}_2\text{CO}_{3(aq)} \longrightarrow 2\text{H}^+_{(aq)} + \text{CO}_3^{2-}_{(aq)}$ Produces a weak acid that partly ionises

1999 Part 3 Answers

- 4.
- (a) 2.5 mol – seems too easy.
 - (b) 0.0015mol
 - (c) 192ppm
 - (d) To ensure that all the SO_3^{2-} is converted to SO_2
 - (e) Change from colourless to purple
- 5.
- (a) $N = c \times v = 0.1000 \times 0.025 = 0.0025\text{mol H}_4\text{Y added}$
 - (b) $N = c \times v = 0.1000 \times 0.00826 = 0.000826\text{ mol H}_4\text{Y inxs}$
 - (c) 0.001674mol used
 - (d) $C = n/v = 0.00167/10 = 0.000167\text{m/L}$
 - (e) Superphosphate is mixed with calcium sulphate OR ammonium sulphate is used as a fertiliser

2000 Part 1 Answers17 c 18 d 19 b 20 b
21 a 22 a**2000 Part 2 Answers**

7 the K_w value is temp dependant
It is neutral as $[\text{H}^+] = [\text{OH}^-]$

8		Total P	Pp of CO	Eq position
	Heat	Incr	Incr	Rhs
	More CH_4	Incr	Incr	Rhs
	Ne is added	Incr	No change	No change
	Halve vol	Incr	Incr	lhs

$$9 \quad a \quad K = \frac{[\text{Fe}(\text{H}_2\text{O})_6]^{3+} [\text{NCS}^-]}{[\text{Fe}(\text{H}_2\text{O})_5\text{NCS}^{2+}]}$$

$$b \quad K = \frac{[\text{Cl}_2][\text{NO}]^2}{[\text{NOCl}]^2}$$

2001 Part 1 Answers

13 a or d 14 a 29 b 30 d

2001 Part 2 Answers

$$7 \quad K = \frac{[\text{Au}(\text{CN})_2^-]^4 [\text{OH}^-]^8}{[\text{O}_2][\text{CN}^-]^8} \quad \text{or} \quad K = \frac{[\text{Au}(\text{CN})_2^-]^4 [\text{OH}^-]^8}{p(\text{O}_2)[\text{CN}^-]^8}$$

$$K = \frac{[\text{Au}(\text{CN})_2^-]^4 [\text{OH}^-]^8}{[\text{H}_2\text{O}]^2 [\text{O}_2][\text{CN}^-]^8} \quad \text{or} \quad K = \frac{[\text{Au}(\text{CN})_2^-]^4 [\text{OH}^-]^8}{[\text{H}_2\text{O}]^2 p(\text{O}_2)[\text{CN}^-]^8}$$

$$K = \frac{[\text{HI}]^2}{[\text{H}_2][\text{I}_2]} \quad \text{or} \quad K = \frac{p(\text{HI})^2}{p(\text{H}_2)p(\text{I}_2)}$$

Acids and bases

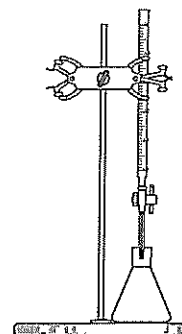

Science as a Human Endeavour

Models and theories are contested and refined or replaced when new evidence challenges them, or when a new model or theory has greater explanatory scope. Davy initially proposed that acids were substances that contained replaceable hydrogen (hydrogen that could be partly or totally replaced by metals) and bases were substances that reacted with acids to form salts and water. The Arrhenius model, which includes only soluble acids and bases, identified acids as substances which produce hydrogen ions in solution and bases as substances which produce hydroxide ions in solution. Subsequently, the Brønsted-Lowry model describes acid-base behaviour in terms of proton donors and proton acceptors. This approach includes a wider range of substances and can be more broadly applied.

Davy Definition :

Sir Humphry Davy (an Englishman) defined acids as substances with replaceable hydrogen. e.g.



And bases formed water and a salt when reacted with acids

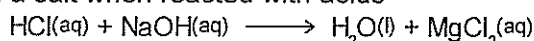

Arrhenius Definition

- acid is a substance which ionises in solution to produce hydrogen ions: acids are very strong if they ionise completely and weak if they ionised only slightly.
- However, it does not give due recognition to the role of the solvent. Also, in some solvents, the acid is not ionised at all, yet it still reacts.
- proton transfer as the common feature of all acid/base systems

Lowry-Brønsted Concept Of Acids And Bases

- (a) acids as proton donating species (molecule or ion)
- As acid is a substance, which in solution, tends to give up protons (hydrogen ions),
- (b) bases as proton accepting species (molecule or ion)
- a base is a substance which tends to accept protons.
- (c) diprotic and polyprotic acids
 - donate 2 or more protons
- (d) amphiprotic species
- Substances which can act both as proton donors and as proton acceptors are called amphiprotic.
$$\text{H}_2\text{PO}_4^- + \text{H}_2\text{O} \rightleftharpoons \text{H}_3\text{PO}_4 + \text{OH}^-$$
$$\text{H}_2\text{PO}_4^- + \text{H}_2\text{O} \rightleftharpoons \text{HPO}_4^{2-} + \text{H}_3\text{O}^+$$

Neutralisation

acid (1) + base (2) \rightleftharpoons conjugate acid of base (2) + conjugate base of acid (1)

- strength of acids may be compared by the extent of their proton transfer to water forming aqueous hydrogen ions
- the Lowry-Brønsted concept of acids and bases has the following advantages:
 - It highlights the fact that the acidity or basicity of a substance depends upon the nature of the solvent as well as that of the substance itself
 - It relates strengths of conjugate acids and bases to those of the parent bases and acids.
 - It explains why solutions of salts have pHs different from 7.

Science Understanding

acids are substances that can act as proton (hydrogen ion) donors and can be classified as monoprotic or polyprotic, depending on the number of protons available for donation

In polyprotic acids the hydrogen ions are released one step at a time

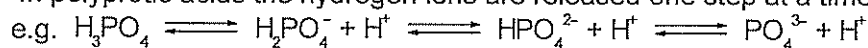

each successive acid step is weaker

the strength of acids is explained by the degree of ionisation at equilibrium in aqueous solution which can be represented by chemical equations and acidity constants (Ka)

You should know HCl, H₂SO₄ and HNO₃ are strong and H₃PO₄ and CH₃COOH are weak

Strength of acids and bases

In Lowry-Brønsted terms, an acid or base is strong if

acid + water → ions

proceeds to virtual completion, and weak if it proceeds only partially.

the relationship between acids and bases in equilibrium systems can be explained using the Brønsted-Lowry model and represented using chemical equations that illustrate the transfer of protons between conjugate acid-base pairs

A big advantage of the Lowry-Brønsted concept is that it allows us to relate the strength of a conjugate base or acid to that of the parent acid or base.

e.g. $\text{HCl} + \text{H}_2\text{O} \longrightarrow \text{H}_3\text{O}^+ + \text{Cl}^-$

here HCl is a strong acid so its conjugate base Cl⁻ is weak

and $\text{CH}_3\text{COOH} + \text{H}_2\text{O} \rightleftharpoons \text{H}_3\text{O}^+ + \text{CH}_3\text{COO}^-$

here CH₃COOH is a weak acid so its conjugate base CH₃COO⁻ is strong.

the hydrolysis of salts of weak acids and weak bases can be represented using equations; the Brønsted-Lowry model can be applied to explain the acidic, basic and neutral nature of salts derived from bases and monoprotic and polyprotic acids

Hydrolysis of Salts and pH

- Most salts are strong electrolytes and exist as ions in aqueous solutions. These ions do not react with water, and have no effect on the pH of their salts.
- Some ions, however, react with water to form either H₃O⁺ or OH⁻. Such a reaction with water is called hydrolysis. Whether a solution of a salt will be acidic, neutral, or basic can be predicted on the basis of the strengths of the acid and base from which the salt was formed. See page 8 of this book.
- You can use the general rules below to help predict the nature of the salt solution:

1. Salt of a strong acid and a strong base yield a neutral solution, pH = 7

example: NaCl (strong acid was HCl, strong base was NaOH)



2. Salt of a weak acid and a strong base yield a cation that hydrolyses, forming OH⁻ ions, pH > 7

example:

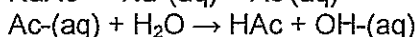
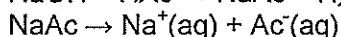
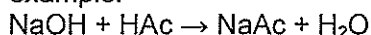

3. Salt of a strong acid and a weak base yield an anion that hydrolyses, forming H⁺ ions, pH < 7

example:

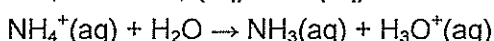
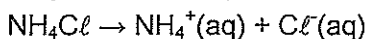
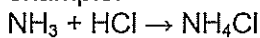

4. Salt of a weak acid and a weak base yield both ions that hydrolyse. May be acidic, neutral or basic.

The pH of the solution is determined by the relative extent to which each ion hydrolyses.

example: ammonium acetate is pH 7 only if NH₄⁺ and Ac⁻ hydrolyse to the same extent

pH of salt solutions

- The anion of a salt formed from a weak acid and a strong base is a weak base, and therefore the pH of the salt solution is greater than 7.
- The cation of a salt formed from a strong acid and a weak base is itself a weak acid, and therefore the pH of the salt solution is less than 7.

buffer solutions are conjugate in nature and resist changes in pH when small amounts of strong acid or base are added to the solution; buffering capacity can be explained qualitatively; Le Châtelier's Principle can be applied to predict how buffers respond to the addition of hydrogen ions and hydroxide ions

Buffer solutions

- A buffer solution is a solution which contains comparable amounts of a weak acid and its conjugate base and which is therefore able to maintain approximately constant pH even when significant amounts of strong acid or strong base are added to it.
- **Buffer:** acetic acid and sodium acetate: CH₃COOH, CH₃COONa, pH 4.6.

How buffers work

The ability of a buffer solution to resist changes in pH is the result of the equilibrium between a weak acid (HA) and its conjugate base (A⁻):



Any alkali added to the solution is consumed by the hydronium ions. These ions are mostly regenerated as the equilibrium moves to the right and some of the acid dissociates into hydronium ions and the conjugate base.

If a strong acid is added, the conjugate base is protonated, and the pH is almost entirely restored. This is an example of Le Châtelier's principle and the common ion effect.

Question : Predict, using Le Châtelier's Principle, how buffers respond to the addition of H⁺ and OH⁻. Explain qualitatively the concept of buffering capacity.

Definition

A buffer solution is one which resists changes in pH when small quantities of an acid or an alkali are added to it. It is made from equal amounts of weak acid and its conjugate or a weak base and its conjugate.. To be a buffer with high buffer capacity it should be of high concentration

Acidic buffer solutions

An acidic buffer solution is simply one which has a pH less than 7. Acidic buffer solutions are commonly made from a weak acid and one of its salts - often a sodium salt.

Alkaline buffer solutions

An alkaline buffer solution has a pH greater than 7. Alkaline buffer solutions are commonly made from a weak base and one of its salts.

water is a weak electrolyte; the self-ionisation of water is represented by $K_w = [\text{H}^+][\text{OH}^-]$ where $K_w = 1.0 \times 10^{-14}$ at 25 °C

The self-ionisation of water is an endothermic process. At 25° it has a $K_a = 10^{-14}$ but at higher temperatures it is larger. E.g. 10^{-8} . Thus the pH at the neutral point will be 4 and the pOH will be 4. So it might be pH 4 but it is neutral not acidic.

$K_w = [\text{H}_3\text{O}^+][\text{OH}^-]$, Which at 298K = 1.00×10^{-14} (mol/L)². The [H₃O⁺] and the [OH⁻] must be equal in pure water and so they are each 10^{-7}

A neutral solution is defined as one in which the hydrogen ion and hydroxide ion concentrations are equal. Hence at 25°C, a neutral solution is one in which the hydrogen ion concentration is 1.00×10^{-7} mol/L.

K_w can be used to calculate the concentration of hydrogen ions or hydroxide ions in solutions of strong acids or bases

You can use $K_w = [\text{H}_3\text{O}^+][\text{OH}^-] = 1.00 \times 10^{-14}$ to calculate [H₃O⁺] from [OH⁻] and vice versa. BUT it is easier to use pH + POH = 14. You will make less errors.

the pH scale is a logarithmic scale and the pH of a solution can be calculated from the concentration of hydrogen ions using the relationship $\text{pH} = -\log_{10} [\text{H}^+]$

Meaning of pH

the pH of a solution is defined as the negative of the logarithm (to base 10) of the hydrogen ion concentration: $\text{pH} = -\log_{10} [\text{H}_3\text{O}^+]$

The symbol "p" means take the $-\log_{10}$ of the value. Thus a solution of 0.001M HCl has pH=3. For a strong base of 0.01M NaOH has a pOH of 2 so has a pH of 14 - 2 = 12. This is useful ! pH + pOH = 14

strong acid solutions

you would be expected to know common examples such as HCl, HNO₃, H₂SO₄

strong base solutions

you would be expected to know common examples such as NaOH, KOH, Ca(OH)₂ (Note although Ca(OH)₂ is has low solubility it is a strong electrolyte)

the resulting solution when strong acid-base solutions are mixed

Be ready for questions like : "50mL of 0.10m HCl is mixed with 200mL of 0.20 M NaOH. Calculate the resulting pH."

acid-base indicators are weak acids, or weak bases, in which the acidic form is a different colour from the basic form

To choose an indicator, we first determine what is present at the equivalence point of the titration, work out the pH of that solution, and then select an indicator which changes colour at that pH. This is called its 'end point'

You do not have to know any indicators. You must be able to pick a suitable one.

Acid	Base	Salt	end point
Strong	strong	Neutral	7
Strong	weak	acidic e.g. NH ₄ ⁺ hydrolyses to form NH ₃ (weak) and H ₃ O ⁺	<7
Weak	strong	basic e.g. CH ₃ COO ⁻ hydrolyses to form CH ₃ COOH (weak) and OH ⁻	>7
Weak	weak	neutral if same conc'n and same Ka	7

volumetric analysis methods involving acid-base reactions rely on the identification of an equivalence point by measuring the associated change in pH, using appropriate acid-base indicators or pH meters, to reveal an observable end point

Volumetric analysis

- Volumetric analysis involving strong acid - strong base, weak acid - strong base and strong acid - weak base, Never titrate weak acids with weak bases.

Titration

- the process of determining the volume of one reactant solution which exactly reacts with a given amount of another reactant
- the equivalence point of a chemical reaction is the point at which amounts of the two reactants are just sufficient to cause complete consumption of both reactants.
- uses: burette, pipette, and conical flask.(Erlenmeyer flask)
- An indicator is chosen so its end point (colour change) occurs at the reaction equivalence point.
- This analysis involves:
 - (a) the use of an appropriate reaction
 - (b) the preparation of a standard solution
 - (c) identification of the end point of a reaction
 - (d) appropriate experimental techniques
 - (e) care and accuracy in the use of equipment

A Brief Summary of Volumetric Chemistry Methods & Volumetric Glassware:

Measuring : Volumetric flasks and measuring cylinders

Delivering : Pipettes and Burettes

- Keep eye level on meniscus
- Read bottom of meniscus
- Must not be used for hot solutions

Volumetric Flask

Standard Solution, : a solution of known concentration.

Solute : that which is dissolved

Solvent : the liquid that dissolves the solute

Solution : The solute and solvent together.

Standard solutions have a mass of solute made up to a known volume - not a known volume added.

Notes on Use

- Clean
- Rinse with distilled water
- Shake out flask
- Dry funnel in neck
- Tip watch glass into beaker
- dissolve using a stirring rod
- transfer all the beaker contents using the funnel
- Wash solute into flask from beaker and funnel
- Remove funnel
- Half fill the flask with solvent
- Swirl to achieve solution it will be clear : i.e. not a suspension that scatters light.
- Add distilled water to within 0.5ml of mark
- Add final liquid drop by drop with teat pipette
- Invert to make homogeneous
- After use rinse and drain

Pipette

Used to deliver an accurate *aliquot*

Notes on Use

- Rinse with distilled water
- Rinse with solution to be used
- Place tip well into solution
- Use pipette filler
- Apply gentle suction
- Rotate the pipette to allow small amounts of air in to lower to the mark
- Allow to drain freely
- Touch the tip on the side of the flask
- Leave the last drop in the pipette

Burette

Used to deliver an accurate *titre*

Notes on Use

- Rinse with distilled water
- Rinse with solution to be used
- Run the rinsing solution through the tap
- Ensure it is clamped and vertical

- Place burette funnel in the top
- Ensure the tap is closed
- Fill to about 0.00
- Remove the funnel
- Turn the tap on so the tip fills.
- Use left hand on burette and right to swirl flask.
- Concordant titres agree within 0.1mL
- Record measurement to 2 decimal places
- You may "shoot" drops off the burette using distilled water
- After use rinse and drain, store inverted

Measuring Cylinder

Used to deliver an approximate volume

Notes on Use

- Rinse with distilled water
- Rinse with solution to be used
- Do not perform reactions in measuring cylinders
- Do not measure hot liquids.

A Primary Standard

If a substance is to be used as a Primary standard it can be used to prepare solutions we can trust

A primary standard should satisfy the following requirements:

1. Purity: It should be available in highly pure form.
2. Temperature Stability: It should be stable (at 110°C- 120°C). No chemical change occurs.
3. Chemical Stability: The substance should be unaltered in air during weighing, this condition implies that it should not be hygroscopic, oxidized by air, or affected by CO₂. The standard should maintain an unchanged composition during storage.
4. Known formula: The formula of the substance must be known. e.g. CuSO₄.7H₂O might be CuSO₄.5H₂O on a dry day
5. Molecular weight: It should have a high molecular weight so that the weighing errors may be negligible.
6. Solubility: It must be readily soluble in the solvent.

data obtained from acid-base titrations can be used to calculate the masses of substances and concentrations and volumes of solutions involved

Note : Amount of substance is measured in mol
Mass of substance is measured in gram
Volume of gas or liquid is measured in mL or L

ATAR Chemistry

Unit 3 : Acids and Bases

Twenty Years of TEE Unit 3 Questions 1990 – 2010

1990 Part 1

6. In which of the following aqueous solutions is there the greatest number of ions?
- (a) 1.00 L of 2.00 mol L⁻¹ CH₃COONa solution. :
 - (b) 1.00 L of 2.00 mol L⁻¹ MgSO₄ solution. ✓
 - (c) 1.00 L of 3.00 mol L⁻¹ CH₃COOH solution.
 - (d) 1.00 L of 1.00 mol L⁻¹ H₂SO₄ solution.
 - (e) 1.00 L of 2.00 mol L⁻¹ Na₂CO₃ solution.
13. Which one of the following aqueous solutions would have a pH greater than 7.0 at 25°C?
- (a) 2.00 mol L⁻¹ sodium acetate solution. ✓
 - (b) 2.00 mol L⁻¹ sodium chloride solution.
 - (c) 2.00 mol L⁻¹ ammonium chloride solution.
 - (d) 2.00 mol L⁻¹ hydrogen chloride solution.
 - (e) 2.00 mol L⁻¹ lead nitrate solution.
14. Which of the following solutions is most likely to have a pH of 10 at 25°C?
- (a) 1 mol L⁻¹ ethanoic acid.
 - (b) 10⁻⁴ mol L⁻¹ hydrochloric acid.
 - (c) 10⁻¹⁰ mol L⁻¹ hydrochloric acid.
 - (d) 10 mol L⁻¹ sodium hydroxide. X WB
 - (e) 10⁻⁴ mol L⁻¹ potassium hydroxide. ←
15. Which one of the following acts as an acid when ammonia is dissolved in an aqueous solution of sodium chloride?
- (a) NH₃
 - (b) Cl⁻
 - (c) NaCl
 - (d) H₂O ✓
 - (e) Na⁺
16. In the titration of a strong acid against an alkali, which of the following statements BEST describes the equivalence point?
- (a) The point at which the rate of the forward reaction equals the rate of the reverse reaction.
 - (b) The point at which the same number of moles of acid and alkali have been put into the flask.
 - (c) The point at which the first sign of a colour change is seen.
 - (d) The point at which equal numbers of moles of H⁺ and OH⁻ have been put into the flask.
 - (e) The point at which the same number of moles of H⁺ and OH⁻ have reacted.
17. What volume of sodium hydroxide solution of pH 12.00 would be required to neutralise 10.00 mL of hydrochloric acid of pH 1.00?
- (a) 1.00 mL
 - (b) 10.0 mL

- (c) 100 mL
 (d) $10.0 \times 1.00/12.00$ mL
 (e) $10.0 \times 12.00/1.00$ mL

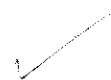

1990 Part 3

1. If 2.440g of a mixture of anhydrous sodium chloride and anhydrous sodium hydrogencarbonate required 18.5mL of 0.705 mol L^{-1} sulphuric acid for complete neutralization. Calculate the percentage by mass of sodium chloride in the mixture

(4 marks)

1991 Part 1

4. Which of the following aqueous solutions would have the lowest pH?
 (a) 0.1 M H_2SO_4
 (b) 0.1 M HNO_3
 (c) 0.1 M KOH
 (d) 0.1M $\text{Ca}(\text{OH})_2$
 (e) 0.1 M NaCH_3COO
16. In which one of the following reactions is the first mentioned substance acting as an acid?
 (a) $\text{C}_6\text{H}_5\text{COO}^-_{(aq)} + \text{H}_2\text{SO}_{3(aq)} \longrightarrow \text{HSO}_3^-_{(aq)} + \text{C}_6\text{H}_5\text{COOH}_{(s)}$
 (b) $2\text{Na}_{(s)} + 2\text{H}_2\text{O}_{(l)} \longrightarrow 2\text{Na}^+_{(aq)} + 2\text{OH}^-_{(aq)} + \text{H}_{2(g)}$
 (c) $\text{H}_{2(g)} + \text{C}_2\text{H}_4(g) \longrightarrow \text{C}_2\text{H}_6(g)$
 (d) $\text{HCO}_3^-_{(aq)} + \text{H}_2\text{O}_{(l)} \longrightarrow \text{H}_2\text{CO}_{3(aq)} + \text{OH}^-_{(aq)}$
 (e) $\text{NH}_4^+_{(aq)} + \text{OH}^-_{(aq)} \longrightarrow \text{NH}_3(g) + \text{H}_2\text{O}_{(l)}$
18. Which one of the following classifications is correct ?

	Sodium carbonate 0.1 mol L ⁻¹ in water	Ammonium chloride 0.1 mol L ⁻¹ in water	Potassium acetate 0.1 mol L ⁻¹ in water
--	---	--	--

- | | | | |
|-----|--------|--------|--------|
| (a) | acidic | Acidic | Basic |
| (b) | basic | Basic | Basic |
| (c) | basic | Acidic | Acidic |
| (d) | basic | Acidic | basic |
| (e) | acidic | Basic | acidic |



1991 Part 2

5. A dilute sulfuric acid solution has a concentration of 0.4905 g L^{-1} . Determine
 (a) the concentration of sulfate ions in mol L^{-1}
 (b) the pH of the solution
 (c) the concentration of the hydroxide ion in mol L^{-1}

(3 marks)

1991 Part 3

1. The active ingredient of a drain cleaning powder is sodium hydroxide. A sample of this powder weighing 11.40 g is dissolved in water and made up to 250.0 mL in a volumetric flask. A 20.00 mL sample of the resulting solution required 18.75 mL of 0.320 mol L^{-1} sulfuric acid for complete neutralisation. You may assume that none of the other ingredients of the drain cleaning powder react with the sulfuric acid.
- How many moles of sulfuric acid were used?
 - How many moles of sodium hydroxide were in the 20.00 mL sample?
 - What is the molar concentration of the sodium hydroxide solution?
 - How many grams of sodium hydroxide are contained in 1.00 kg of the drain cleaning powder?

(5 marks)

1992 Part 1

15. Which one of the following is commonly used as a primary standard in volumetric analysis?
 (a) Sodium hydroxide
 (b) Sulfuric acid
 (c) Potassium permanganate

- (d) Hydrogen peroxide ✓
(d) Sodium carbonate

17. What is the pH of $1.0 \times 10^{-3} \text{ mol L}^{-1}$ acetic acid (ethanoic acid)?
(a) Below 3
(b) Exactly 3 ✓
(c) Between 3 and 7
(d) Exactly 7
(e) Above 7

1992 Part 3

9. When ammonium chloride is dissolved in water, the pH of the solution is not equal to 7. State whether the pH of the solution will be greater or less than 7. Write one or more suitable chemical equations to explain your answer. [4 marks]

1993 Part 1

1. 25.00 mL of 1.50 mol L^{-1} hydrochloric acid is made up to 100.00 mL with distilled water. What is the concentration of the solution produced?
(a) 0.375 mol L^{-1}
(b) 0.500 mol L^{-1}
(c) 1.00 mol L^{-1}
(d) 4.50 mol L^{-1}
(e) 6.00 mol L^{-1}
10. Which of the following solutions will have the highest electrical conductivity?
(a) 0.10 mol L^{-1} acetic acid (ethanoic acid)
(b) 0.10 mol L^{-1} ammonia
(c) 0.10 mol L^{-1} ammonium acetate
(d) 0.10 mol L^{-1} ethanol
(e) 0.10 mol L^{-1} phosphoric acid
18. In which one of the following processes is water acting as a base?
(a) $\text{NH}_3 + \text{H}_2\text{O} \longrightarrow \text{NH}_4^+ + \text{OH}^-$
(b) $\text{CH}_3\text{CO}_2^- + \text{H}_2\text{O} \longrightarrow \text{CH}_3\text{COOH} + \text{OH}^-$
(c) $\text{O}_2\text{CCO}_2^{2-} + \text{H}_2\text{O} \longrightarrow \text{HOCCO}_2^- + \text{OH}^-$ ✓
(d) $\text{O}^{2-} + \text{H}_2\text{O} \longrightarrow 2\text{OH}^-$
(e) $\text{HS}^- + \text{H}_2\text{O} \longrightarrow \text{S}^{2-} + \text{H}_3\text{O}^+$
19. Calcium hydroxide is a strong electrolyte. What is the pH of $0.010 \text{ mol L}^{-1} \text{ Ca(OH)}_2$?
(a) 1.7
(b) 2.0
(c) 7.0
(d) 12.0
(e) 12.3
20. Since strong bases such as NaOH and KOH absorb moisture from the air, they cannot be used in volumetric analysis as primary standards. A standard hydroxide solution can however be prepared by dissolving a known quantity of mercury(II) oxide in excess KBr solution, when the following reaction occurs
- $$\text{HgO} + 4 \text{Br}^- + \text{H}_2\text{O} \longrightarrow \text{HgBr}_4^{2-} + 2\text{OH}^-$$
- When 0.1000 mol of HgO is dissolved in a solution of 1.5 mol of KBr in 300 mL of water and the solution made up to 1.0000 L , what is the hydroxide ion concentration in the standard solution?
(a) $0.1000 \text{ mol L}^{-1}$
(b) $0.3750 \text{ mol L}^{-1}$
(c) $0.4750 \text{ mol L}^{-1}$

- (d) 1.600 mol L^{-1}
 (e) None of these

21. An acetic acid (ethanoic acid) solution is titrated with sodium hydroxide solution (in the burette), using methyl orange (end point 5) as the indicator. Which one of the following statements about this titration is true?
- (a) The end point and equivalence point occur at the same time.
 (b) The end point occurs after the equivalence point.
 (c) The end point occurs before the equivalence point
 (d) Whether the end point or equivalence point occurs first depends on the relative concentrations of acid and base.
 (e) No end point would be observed at any time.
22. In a titration procedure, 25.00 mL of a sodium hydroxide solution is diluted to 500.00 mL using a volumetric flask, and 25.00 mL samples transferred by pipette to conical flasks for titration with standard hydrochloric acid from a burette. Which of the following items of glassware
- burette
 - pipette
 - conical flasks
 - volumetric flask
- can be rinsed with water immediately before use, without making the titrations inaccurate?
- (a) The burette and pipette only
 (b) The burette, pipette, conical flasks and volumetric flask
 (c) The conical flasks only
 (d) The conical flasks and volumetric flask only
 (e) The volumetric flask only

1993 Part 2

9. A series of four HCl solutions with different concentrations was prepared, and tested with the indicator erythrosin. The results are set out below.

pH	Erythrosin Colour
1.0	Yellow
2.0	Yellow
3.0	Orange
4.0	Red

On the basis of the above experiment, what can be concluded about the pH of two unknown solutions which when tested with erythrosin gave the following results?

Unknown solution	Erythrosin Colour	pH
A	Orange	
B	Red	

[2 marks]

10. (a) The pH of a $0.1 \text{ mol L}^{-1} \text{ NaHCO}_3$ solution is 8.3. With the help of one or more suitable chemical equations explain why the pH is greater than 7.
 (b) The pH of a $0.1 \text{ mol L}^{-1} \text{ NaHSO}_4$ solution is 1.2. With the help of one or more suitable chemical equations explain why the pH is less than 7.

1994 Part 1

13. Which one of the following solutions has a pH greater than 7?
- (a) 0.1 mol L^{-1} ammonium sulfate
 (b) 0.1 mol L^{-1} iron(II) chloride
 (c) 0.1 mol L^{-1} magnesium nitrate
 (d) 0.1 mol L^{-1} potassium acetate (potassium ethanoate)
 (e) 0.1 mol L^{-1} sodium nitrate

14. A dilute solution of ammonia (in the titration vessel) is titrated with dilute hydrochloric acid (from the burette), and the following graph is obtained.

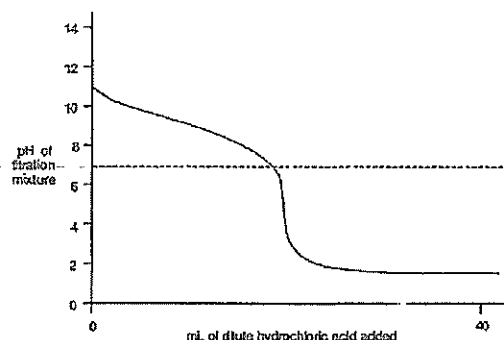

If bromothymol blue, which changes colour around pH 7, is used as indicator, which one of the following statements is true?

- The end-point occurs before the equivalence-point.
- The end-point occurs at the equivalence-point.
- The end-point occurs after the equivalence-point.
- There is no equivalence-point because it is the wrong indicator.
- The colour does not change because it is the wrong indicator.

1994 Part 3

5. A packet of pure chalcocite, Cu_2S , has over a period of time become partially oxidised and hydrated, giving $\text{CuSO}_4 \cdot 5\text{H}_2\text{O}$ and mixed oxides of copper. This mixture of Cu_2S , $\text{CuSO}_4 \cdot 5\text{H}_2\text{O}$ and oxides of copper was treated as follows.

- A representative 1025 g sample was washed with water to remove the copper sulfate, and then dried and reweighed. The mass of the washed and dried sample (consisting of Cu_2S and copper oxides) was 919 g. Calculate the percentage by mass of copper sulfate pentahydrate in the original packet. [2 marks]

- A 0.536 g sample of the dried washed material (Cu_2S and copper oxides) was roasted in an excess of oxygen and the gases treated so that all the sulfur in the sample was converted into sulfuric acid.

The sulfuric acid solution from the 0.536 g sample was titrated with sodium hydroxide solution, and required 27.53 mL of $0.2000 \text{ mol L}^{-1}$ NaOH solution for an end-point with phenolphthalein.

- Determine the number of moles of sulfur in the 0.536 g sample. [3 marks]

- Calculate the percentage by mass of Cu_2S in the dried sample. [4 marks]

- Calculate the percentage by mass of Cu_2S in the original packet. [2 marks]

- Calculate the percentage by mass of mixed copper oxides in the original packet. [1 mark]

1995 Part 1

15. Which of the following are Brønsted-Lowry acid-base reactions?

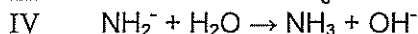
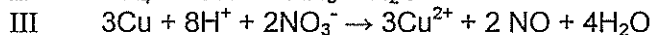
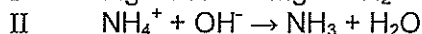
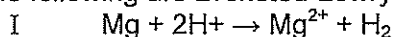

- I, II and III only
 - I and III only
 - II, III and IV only
 - II and IV only
 - IV only
16. Which of the following best describes 10 mol L^{-1} ammonia?
- a dilute solution of a weak base
 - a concentrated solution of a weak base
 - a dilute solution of a strong base
 - a concentrated solution of a strong base
 - a strong solution of a weak base
17. Which one of the following solutions has a pH less than 7?
- 0.01 mol L^{-1} ammonium chloride
 - 0.01 mol L^{-1} calcium hydroxide

- (c) 0.01 mol L⁻¹ potassium nitrate
- (d) 0.01 mol L⁻¹ sodium acetate (sodium ethanoate)
- (e) 0.01 mol L⁻¹ sodium phosphate

1995 Part 2

13. Write the equation for the industrial synthesis of ammonia. This reaction takes place exceedingly slowly at room temperature and pressure. List three ways in which chemists control reaction conditions to speed up the process. [4 marks]
14. Calculate the pH of 0.0250 mol L⁻¹ rubidium hydroxide, RbOH. [3 marks]

1995 Part 3

1. An analyst has a pure substance 'A' which is a weak acid and she decides to determine its molecular weight by titration.

She dissolves 1.3867 g of 'A' in water and makes the solution up to 250.0 mL in a volumetric flask. She then titrates 20.00 mL portions of the solution of 'A' with 0.09826 mol L⁻¹ sodium hydroxide from the burette using phenolphthalein as indicator, and records the following titration figures.

Final reading (mL)	20	19.5	18.32	17.77	18.87
Initial reading (mL)	0.11	1.32	0.67	0.08	1.20

- (a) Calculate the appropriate value for the volume of sodium hydroxide solution required for titration. [1 mark]
- (b) Assume that 'A' is a monoprotic acid and calculate the number of moles of 'A' in the 1.3867 g of 'A'. [5 marks]
- (c) Use this value to calculate the molecular weight of 'A'. [2 marks]
- (d) Assume that 'A' is a diprotic acid and calculate its molecular weight. [1 mark]
- (e) Assume that 'A' is a triprotic acid and calculate its molecular weight. [1 mark]

1996 Part 1

7. A stock solution contains 1.00 g L⁻¹ copper (as Cu²⁺). What volume of this solution must be diluted to 50.0 mL to give a solution containing 5.00 mg L⁻¹ copper?
- (a) 0.100 mL
 - (b) 0.250 mL
 - (c) 1.00 mL
 - (d) 2.50 mL
 - (e) 10.0 mL

14. A chemist carries out a titration and records the following figures in her report book.

Final reading (mL)	23	22.53	22.59	22.01	22.37
Initial reading (mL)	0.02	1.07	1.15	1.56	0.89

What titration figure should she use in her subsequent calculation?

- (a) 21.208 mL
 - (b) 21.21 mL
 - (c) 21.46 mL
 - (d) 21.56 mL
 - (e) 21.562 mL
15. Solid sodium carbonate is added to deionised water at pH 7.00. Which one of the following statements is correct?
- (a) The pH decreases because of the reaction of CO₃²⁻ with water.
 - (b) The pH decreases because of the reaction of Na⁺ with water.
 - (c) The pH increases because of the loss of carbon dioxide.
 - (d) The pH increases because of the reaction of CO₃²⁻ with water.
 - (e) The pH increases because of the reaction of Na⁺ with water.

16. Which one of the following species acts as an acid when ammonia gas is passed into a water solution of sodium chloride?
- Cl^-
 - H_2O
 - Na^+
 - NH_3
 - None of these species, since no acid/base reaction occurs.
17. A 0.100 mol L^{-1} acetic acid (ethanoic acid) solution is 1.34% ionised. What is the pH of the solution?
- 0.34
 - 0.87
 - 1.00
 - 1.34
 - 2.87
18. A series of four NaOH solutions with different concentrations was prepared, and tested with the indicator Brilliant Cresyl Blue. The results are set out below.

pH	Colour with Brilliant Cresyl Blue
10.0	Blue
11.0	Green
12.0	Yellow
13.0	Yellow

On the basis of the above experiment, what can you conclude about the pH of two unknown solutions which when tested with Brilliant Cresyl Blue gave the following results?

Unknown solution	Colour with Brilliant Cresyl Blue
A	Blue
B	Yellow

- The pH of A is 10, and the pH of B is 12.
- The pH of A is 10, and the pH of B is between 12 and 13.
- The pH of A is 10, and the pH of B is 12 or more.
- The pH of A is 10 or less, and the pH of B is between 12 and 13.
- The pH of A is 10 or less, and the pH of B is 12 or more.

1996 Part 3

3. A brand of toilet cleaner claims on the label to contain sodium hydrogensulfate, NaHSO_4 , 410 g/kg. A chemist wishes to verify this claim by carrying out a volumetric analysis, using a standard solution of $0.04343 \text{ mol L}^{-1}$ sodium hydroxide.
- She decides to make a solution of the toilet cleaner in a 500.0 mL volumetric flask that will give a titre of 20.00 mL when titrated against 20.00 mL of the sodium hydroxide solution. Assume that the claimed contents of the cleaner are correct, and calculate the mass of the cleaner she should take to make the 500.0 mL of solution. [5 marks]
 - By incredible good fortune she weighs out exactly the mass of cleaner she has calculated in part (a). Using phenolphthalein as indicator, she then finds that a titre of 18.00 mL of the cleaner solution is needed for reaction with 20.00 mL of the sodium hydroxide solution. What is the actual concentration of the cleaner in g/kg of sodium hydrogensulfate? [2 marks]

1997 Part 1

2. 0.0520 mol of sodium carbonate is dissolved in enough water to make 100.0 mL of solution. What is the concentration of the sodium carbonate in mol L^{-1} ?
- $0.00520 \text{ mol L}^{-1}$
 - $0.0260 \text{ mol L}^{-1}$
 - $0.0520 \text{ mol L}^{-1}$

- (d) 0.520 mol L⁻¹
 (e) 5.20 mol L⁻¹
15. Which one of the following solutions has a pH greater than 7?
 (a) 0.010 mol L⁻¹ aluminium nitrate
 (b) 0.010 mol L⁻¹ ammonium chloride
 (c) 0.010 mol L⁻¹ barium nitrate
 (d) 0.010 mol L⁻¹ rubidium chloride
 (e) 0.010 mol L⁻¹ sodium acetate (sodium ethanoate)
16. Sodium hydroxide solution is added from a burette to 1.000 L of a solution of 1.000 mol L⁻¹ phosphoric acid. How many moles of NaOH are required to reach the final equivalence point?
 (a) 1.00 mol
 (b) between 1.00 mol and 2.00 mol
 (c) 2.00 mol
 (d) between 2.00 mol and 3.00 mol
 (e) 3.00 mol
17. The indicator methyl red changes colour over the pH range 4.4 to 6.2, and the indicator phenolphthalein changes colour over the range 8.3 to 10.0. Which one of the following statements about the titration of 0.100 mol L⁻¹ ammonia with 0.100 mol L⁻¹ hydrochloric acid is true?
 (a) Methyl red is a suitable indicator because the solution is acidic at the equivalence point.
 (b) Methyl red is a suitable indicator because the solution is basic at the equivalence point.
 (c) Phenolphthalein is a suitable indicator because the solution is acidic at the equivalence point.
 (d) Phenolphthalein is a suitable indicator because the solution is basic at the equivalence point.
 (e) Either methyl red or phenolphthalein is suitable because the solution is neutral at the equivalence point.
18. A drop of water is added to a litre of pure liquid acetic acid (ethanoic acid) and the mixture shaken. Which of the following statements best describes the resulting solution?
 (a) It is a concentrated solution of a strong acid.
 (b) It is a dilute solution of a strong acid.
 (c) It is a concentrated solution of a weak acid.
 (d) It is a dilute solution of a weak acid.
 (e) It is not a true solution because there is insufficient solvent.
19. In which one of the following processes is water acting as a base?
 (a) $\text{HNO}_3 + \text{H}_2\text{O} \longrightarrow \text{H}_3\text{O}^+ + \text{NO}_3^-$
 (b) $\text{H}_2\text{O}(l) \longrightarrow \text{H}_2\text{O}(g)$
 (c) $\text{NH}_3 + \text{H}_2\text{O} \longrightarrow \text{NH}_4^+ + \text{OH}^-$
 (d) $\text{NaCl}(s) + \text{H}_2\text{O}(l) \longrightarrow \text{Na}^+(\text{aq}) + \text{Cl}^-(\text{aq})$
 (e) $\text{O}^{2-} + \text{H}_2\text{O} \longrightarrow 2 \text{OH}^-$

1997 Part 3

2. You may analyse a sample for arsenic in the following way.
 Heat the sample strongly with excess sodium peroxide so that the mixture melts; the arsenic is converted to sodium arsenate:

$$2 \text{As} + 5 \text{Na}_2\text{O}_2 \longrightarrow 2 \text{Na}_3\text{AsO}_4 + 2 \text{Na}_2\text{O}$$

 Allow the product to cool, and dissolve it in water; the sodium arsenate dissolves:

$$\text{Na}_3\text{AsO}_4 \longrightarrow 3 \text{Na}^+ + \text{AsO}_4^{3-}$$

 Then add dilute nitric acid, boil the solution, and adjust the pH to 8 with sodium hydroxide solution and acetic acid (ethanoic acid) solution; the arsenate ion is converted to dihydrogenarsenate ion:

$$\text{AsO}_4^{3-} + 2 \text{H}^+ \longrightarrow \text{H}_2\text{AsO}_4^-$$

 Add silver nitrate solution to precipitate silver arsenate:

$$\text{H}_2\text{AsO}_4^- + 3 \text{Ag}^+ \longrightarrow \text{Ag}_3\text{AsO}_4 + 2 \text{H}^+$$

Filter the silver arsenate, wash it, and dissolve it in dilute nitric acid to produce silver ion:

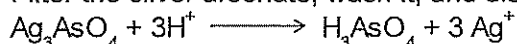

Titrate the silver ion with potassium thiocyanate solution, using iron(III) ion as indicator:



A 0.0603 g sample of commercial arsenic metal is treated as described, and ultimately when the processed sample is titrated, it requires 23.38 mL of 0.10034 mol L⁻¹ potassium thiocyanate solution.

- (a) Use the above equations to calculate how many moles of thiocyanate ion will react with the silver ion produced from 1 mole of arsenic.

[3 marks]

- (b) Use this value to calculate the percentage by mass of arsenic in the sample.

[5 marks]

1998 Part 1

1. Enough water is added to 5.0 mL of 4.0 mol L⁻¹ HCl to make 50.0 mL of solution. Which one of the following gives the number of moles of Cl⁻ present in the 50.0 mL of solution?
- (a) 0.0010 mol
(b) 0.020 mol
(c) 0.050 mol
(d) 0.40 mol
(e) 0.50 mol
15. What is the pH of 1.5 × 10⁻⁴ mol L⁻¹ Ca(OH)₂, assuming that Ca(OH)₂ is completely dissociated in a water-solution?
- (a) 3.5
(b) 3.8
(c) 4.2
(d) 10.2
(e) 10.5
16. Which one of the following would cause the percentage ionisation of a weak acid to decrease?
- (a) addition of a strong acid
(b) addition of a strong base
(c) addition of a weak base
(d) dilution with water
(e) none of the above
17. Which of the following descriptions best distinguishes a weak acid from a strong acid?
- (a) All organic acids are weak acids and all inorganic acids are strong acids.
(b) A solution of a weak acid has more hydroxide ions than hydrogen ions.
(c) A solution of a weak acid contains its own molecules.
(d) A weak acid is obtained by diluting a strong acid.
(e) The acidic hydrogen atom of a weak acid is more weakly bonded to the rest of the molecule.
19. A nitric acid solution is to be standardised using 0.09937 mol L⁻¹ potassium hydroxide. Which of the following indicators would be suitable?
- I methyl orange (changes colour around pH 4)
II bromothymol blue (changes colour around pH 7)
III phenolphthalein (changes colour around pH 9)
- (a) I only
(b) II only
(c) III only
(d) I and III only
(e) all of I, II and III

1998 Part 2

12. Not all solutions of salts are neutral. Complete the following table stating whether the following solutions are acidic (pH < 7), neutral (pH = 7) or basic (pH > 7).

Solute (0.1 mol L ⁻¹)	pH of solution Write 'acidic', 'neutral', or 'basic'
NH ₄ Cl	

Na ₂ CO ₃	
NaCl	
KCH ₃ CO ₂	

[4 marks]

1998 Part 3

3. A copper sulfide ore was analysed by iodometry in the following way. The ore was finely crushed and a representative sample of 6.056 g was brought into solution with a mixture of concentrated hydrochloric acid and concentrated nitric acid. The excess hydrochloric and nitric acids were removed by heating with a little concentrated sulfuric acid. The remaining solution was quantitatively transferred into a 250.0 mL volumetric flask and the solution made up to the mark with water. 25.00 mL portions of the above solution were each treated as follows. Sodium acetate was added to bring the pH to 4. Then an excess of potassium iodide solution was added, and iodine was liberated according to the following equation.

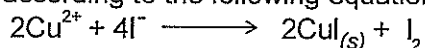

Each portion was titrated with 0.05103 mol L⁻¹ sodium thiosulfate (Na₂S₂O₃) using starch indicator (which was added towards the end of the titration). The following figures were obtained.

Final reading (mL)	17	16.5	15.68	15.12	16.28
Initial reading (mL)	0.22	1.10	0.66	0.06	1.24

The equation for the reaction of iodine with sodium thiosulfate is as follows:

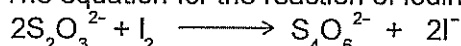

Starch is blue in the presence of I₂. The end-point is taken to be the loss of all blue colour.

- (a) (i) How many moles of iodine are liberated from one mole of copper(II) ion? [1 mark]
- (ii) How many moles of thiosulfate ion are required for one mole of iodine? [1 mark]
- (iii) How many moles of thiosulfate ion are required for one mole of copper(II) ion? [1 mark]
- (b) What titration volume should you use in the calculation? Show your working. [1 mark]
- (c) Calculate the percentage by mass of copper in the ore. Show your working. [5 marks]

4. The Kjeldahl method is used to analyse for nitrogen in an organic substance. The substance is treated with concentrated H₂SO₄, using anhydrous CuSO₄, as a catalyst; all nitrogen is converted into NH₄⁺ ion. The mixture is then treated with excess OH⁻ to convert the NH₄⁺ ion into NH₃. The NH₃, is boiled off and absorbed in an excess of dilute HCl.

In a Kjeldahl determination 1.2540 g of dried pet food was heated for an hour with concentrated H₂SO₄ and anhydrous CuSO₄ (together with K₂SO₄ to raise the boiling-point of the reaction mixture).

On cooling the reaction mixture, Zn pieces and an excess of concentrated NaOH solution were added and the flask quickly

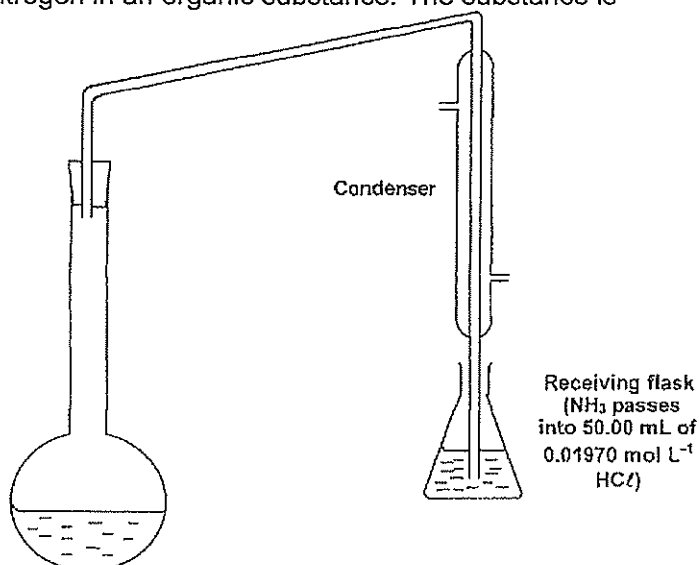

attached to a distillation apparatus as shown below. The mixture was gently boiled to drive the NH_3 into the receiving flask. (The Zn dissolves to give $\text{Zn}(\text{OH})_4^{2-}$ and H_2 gas; the H_2 gas helps sweep out all the NH_3) The NH_3 was distilled into 50.00 mL of 0.01970 mol L^{-1} HCl.

- (a) Calculate the original number of moles of H^+ in the solution in the receiving flask before any NH_3 was absorbed. Show your working. [1 mark]
- (b) After the NH_3 had been absorbed by the HCl solution, the excess HCl was titrated with 0.1000 mol L^{-1} NaOH (in the burette). Methyl orange was used as indicator; 5.62 mL of NaOH solution was needed for the colour change. Calculate the number of moles of H^+ in this solution after the absorption of the NH_3 . Show your working. [2 marks]
- (c) Calculate the number of moles of NH_3 absorbed by the HCl solution, and hence the percentage by mass of nitrogen in the 1.2540 g of dried pet food. Show your working. [5 marks]
- (d) During the decomposition of the pet food (with H_2SO_4 , CuSO_4 and K_2SO_4) there is no stopper on the flask. Why is nitrogen not lost? [1 mark]

1999 Part 1

15. Which of the following best describes the equivalence point in an acid-base titration?
- the point at which chemical equilibrium is reached and no further reaction will occur
 - the point at which equal moles of reactants have been mixed
 - the point at which the indicator changes colour
 - the point at which the stoichiometric amount of reactant has been added
16. Which one of the following correctly arranges 0.1 mol L^{-1} solutions of the substances in order of increasing pH?
- NaOH CH_3COOH NH_3 HCl
 - CH_3COOH HCl NaOH NH_3
 - HCl CH_3COOH NH_3 NaOH
 - HCl NH_3 CH_3COOH NaOH
17. A series of four HCl solutions with different concentrations was prepared, and tested with the indicator Methyl Yellow. The results are set out below.
- | pH | Colour with Methyl Yellow |
|----|---------------------------|
| 1 | red |
| 2 | red |
| 3 | orange |
| 4 | yellow |

On the basis of the above experiment, what can you conclude about the pH of two unknown solutions which, when tested with Methyl Yellow, gave the following results?

Unknown Solution	Colour with Methyl Yellow
A	red
B	yellow

- The pH of A is between 1 and 2, and the pH of B is 4.
- The pH of A is between 1 and 2, and the pH of B is 4 or more.
- The pH of A is 1 or 2, and the pH of B is 4.
- The pH of A is 2 or less, and the pH of B is 4 or more.

1999 Part 2

4. Consider 0.1 mol L^{-1} solutions of
- sodium hydroxide
 - ammonium chloride
 - sulfuric acid, and
 - acetic acid (ethanoic acid).

- (a) Which solution would have the lowest electrical conductivity? Explain your answer.
 (b) Which solution would have the highest pH? Explain your answer.
 (c) Which solution would have the highest concentration of ions? Explain your answer.

[6 marks]

5. Distilled water, which has been exposed to air, has a pH of about 5. When it is boiled and then cooled, the pH has changed to 7. The pH of the distilled water prepared in this way then slowly falls back to about 5. Explain with the aid of equations the role of carbon dioxide in these observations.

3 marks

1999 Part 3

4. Sodium sulfite (Na_2SO_3) can be used as a preservative in hamburgers. In an experiment to determine the amount of Na_2SO_3 in a sample of hamburger, the following steps were followed.

Step 1: 1.00 kg of minced meat was boiled with an excess of dilute sulfuric acid.

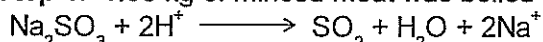

Step 2: The sulfur dioxide gas released was completely absorbed in an excess of sodium hydroxide solution.

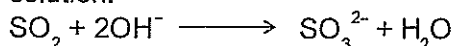

Step 3: The resulting solution was acidified with excess dilute sulfuric acid and titrated with $0.02023 \text{ mol L}^{-1}$ potassium permanganate. 30.08 mL of the potassium permanganate solution were required to reach the end-point.

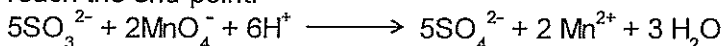

- (a) How many moles of SO_3^{2-} are required to react completely with 1 mole of MnO_4^- ? [2 marks]
 (b) Calculate the number of moles of Na_2SO_3 present in 1.00 kg of hamburger meat. [5 marks]
 (c) Government chemists often express the amount of Na_2SO_3 in meats as parts per million (ppm) [1 ppm = 1 mg Na_2SO_3 in 1 kg of meat]. Express the amount of Na_2SO_3 in the 1.00 kg meat sample in parts per million. [2 marks]
 (d) In step 1, why must the dilute sulfuric acid be in excess? [1 mark]
 (e) In step 3, what colour change in the reaction vessel would you observe at the end-point? [1 mark]

5. In a method for volumetric determination of sulfate ion, the SO_4^{2-} ion is precipitated as PbSO_4 by the addition of Pb^{2+} . The PbSO_4 is then analysed for Pb and the number of moles of SO_4^{2-} ion is equal to the number of moles of Pb in the precipitate. The amount of lead is determined by titration using a compound symbolised as H_4Y . [This compound is actually called 1,2-diaminoethane-N,N',N',N'-tetraethanoic acid.]

A known amount of H_4Y is added to the precipitate, bringing it into solution.

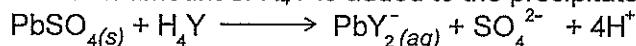

Then the amount of excess H_4Y is determined by titration with standard lead nitrate.

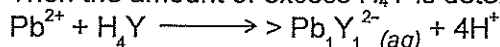

From this, the amount of Pb^{2+} in the PbSO_4 , and hence the amount of SO_4^{2-} ion in the sample, can be calculated.

The following results were obtained for a sample of ground water analysed as above.

Volume of ground water sample:	10.00 L
Volume of $0.1000 \text{ mol L}^{-1}$ H_4Y added to the precipitate:	25.00 mL
Volume of $0.1000 \text{ mol L}^{-1}$ $\text{Pb}(\text{NO}_3)_2$ required to titrate excess H_4Y :	8.26 mL

- (a) Calculate the total number of moles of H_4Y added to the precipitate. [2 marks]
 (b) Calculate the number of moles of H_4Y in excess. [2 marks]
 (c) Calculate the number of moles of H_4Y that combined with the PbSO_4 . [2 marks]
 (d) Calculate the concentration of the SO_4^{2-} ion in the ground water. [3 marks]

2000 Part 1

13. For the reaction described by the following equation: $\text{NH}_4^+ + \text{OH}^- \rightarrow \text{NH}_3 + \text{H}_2\text{O}$ which one of the following statements is correct?
- (a) NH_4^+ is behaving as an acid.
 - (b) NH_4^+ is behaving as a base.
 - (c) NH_4^+ is oxidised.
 - (d) NH_4^+ is reduced.
14. The pH of 0.050 mol L⁻¹ solution of hydrogen cyanide is 6.40. What percentage of the hydrogen cyanide in this solution has ionised?
- (a) $4.0 \times 10^{-7} \%$
 - (b) $8.0 \times 10^{-6} \%$
 - (c) $4.0 \times 10^{-5} \%$
 - (d) $8.0 \times 10^{-4} \%$
15. Which one of the following correctly defines an acid according to the Brønsted-Lowry theory?
- (a) accepts H⁺ ions in water
 - (b) forms H⁺ ions in water
 - (c) H⁺ acceptor
 - (d) H⁺ donor
16. A chemist carries out a titration and records the following values in the report book.

Final reading (mL)	11.6	22.00	32.41	42.07	11.47
Initial reading (mL)	0.20	11.60	22.00	32.41	1.05

What titration value should the chemist use in a subsequent calculation?

- (a) 10.22
- (b) 10.41
- (c) 10.46
- (d) none of these

2000 Part 2

5. Answer the following questions about primary standards used in volumetric analysis.
- a) What are two characteristics of a primary standard?
 - b) Why is a primary standard often required for use in volumetric analysis?

2001 Part 1

Questions 13 and 14 are both about the following experiment.

29. Which one of the following statements about 1.00 x 10⁻⁸ mol L⁻¹ HCl is correct?
- (a) The pH is 6.
 - (b) The pH is a little less than 7.
 - (c) The pH is 8.
 - (d) Such a solution cannot exist.
30. A chemist measures the pH of four 1.0 x 10⁻² mol L⁻¹ acid solutions, and obtains the following results.

Experiment	Solution	pH
1	1.0 x 10 ⁻² M CH ₃ COOH	3.4
2	1.0 x 10 ⁻² M H ₃ PO ₄	2.2
3	1.0 x 10 ⁻² M HNO ₃	2.0 ;
4	1.0 x 10 ⁻² M H ₂ SO ₄	1.4

Which experimental result must be incorrect?

- (a) experiment 1
- (b) experiment 2
- (c) experiment 3
- (d) experiment 4

2001 Part 2

5. (a) A 0.1 mol L^{-1} water-solution of Na_2HPO_4 has a pH of about 10. Explain this, using an equation or equations. [3 marks]
- (b) A 0.1 mol L^{-1} water-solution of $\text{NH}_4\text{CH}_3\text{COO}$ (ammonium acetate, also known as ammonium ethanoate) has a pH of approximately 7. Explain this, using at least two equations. [4 marks]

2002 Part 1

20 For the following equation

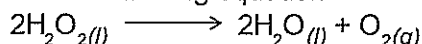

which one of the following statements is true?

- (a) Hydrogen peroxide is acting as an acid.
(b) Hydrogen peroxide is acting as an acid and a base.
(c) Hydrogen peroxide is acting as an oxidising agent only.
(d) Hydrogen peroxide is acting as an oxidising and reducing agent.
30. If a solution contains $1.35 \times 10^{-3} \text{ mol L}^{-1}$ of NaCl , what is the concentration in ppm of Na^+ ? (Assume the density of the solution is 1.00 g mL^{-1} .)
- (a) 1350 ppm
(b) 78.9 ppm
(c) 47.9 ppm
(d) 31.0 ppm

2002 Part 3

5. The official analysis method for aspirin (acetylsalicylic acid) is to dissolve a sample in sodium hydroxide solution and titrate the excess hydroxide with standard hydrochloric acid, using phenol red indicator. The reaction of aspirin with hydroxide is given by:

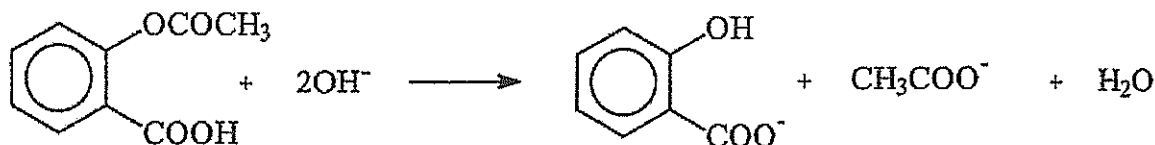
**Acetylsalicylic acid**

To analyse a supply of aspirin tablets claimed to contain 300 mg of acetylsalicylic acid in each tablet, 20 tablets weighing a total of 7.576 g were crushed and a sample of powder weighing 0.619 g was gently boiled for 10 minutes with 30.00 mL of **approximately** 0.5 mol L^{-1} NaOH. After cooling, the solution was titrated with 0.548 mol L^{-1} HCl using phenol red indicator. 17.62 mL of HCl was required.

In a separate 'blank' titration, 30.00 mL of the same approximately 0.5 mol L^{-1} NaOH was gently boiled for 10 minutes, cooled and titrated with the standard 0.548 mol L^{-1} HCl. The volume of HCl required was 27.65 mL.

- (a) How many moles of sodium hydroxide were consumed in the reaction with the 0.619 g of powdered sample? [4 marks]
- (b) What mass of acetylsalicylic acid, $\text{C}_9\text{H}_8\text{O}_4$, was in the 0.619 g sample? [2 marks]
- (c) How many tablets does 0.619 g of powder represent? [1 mark]
- (d) What is the mass of acetylsalicylic acid per tablet? [2 marks]
- (e) The British Pharmacopoeia (an authoritative catalogue of drugs) requires that aspirin tablets contain 95-105% of the mass of acetylsalicylic acid claimed. Do the tablets fit this requirement? [1 mark]

2003 Part 1

27. Consider the following three statements (I - III) about neutralisation reactions.
- I A neutralisation reaction is a reaction between an acid and a base
 - ii At the equivalence point of a neutralisation reaction the pH of the resulting solution will be 7.
 - III Salts are obtained from neutralisation reactions.

Which statement or combination of statements is always correct?

- (a) Only I
 - (b) Only I and II
 - (c) Only I and III
 - (d) I, II and III
28. What is the pH of 0.0050 mol L⁻¹ solution of Ba(OH)₂?
- (a) 2.00
 - (b) 2.30
 - (c) 11.70
 - (d) 12.00
29. Which one of the following equations does not represent the donation and acceptance of protons?
- (a) $\text{Zn} + 2\text{H}^+ \rightleftharpoons \text{Zn}^{2+} + \text{H}_2$
 - (b) $\text{NH}_3 + \text{OH}^- \rightleftharpoons \text{NH}_2^- + \text{H}_2\text{O}$
 - (c) $\text{HOCl} + \text{C}_6\text{H}_5\text{COO}^- \rightleftharpoons \text{OCl}^- + \text{C}_6\text{H}_5\text{COOH}$
 - (d) $\text{C}_6\text{H}_5\text{COOH} + \text{HCO}_3^- \rightleftharpoons \text{C}_6\text{H}_5\text{COO}^- + \text{H}_2\text{CO}_3$

2003 Part 2

8. The pH of a 0.0010 mol L⁻¹ solution of HCl is 3. The pH of a 1.0 mol L⁻¹ solution of CH₃COOH is also about 3. Explain these observations using equations where appropriate.

2003 Part 3

5. In a test to determine the level of alcohol in the blood of a motorist, 5.00 mL of blood was added to 100.0 mL of 0.005961 mol L⁻¹ acidified potassium dichromate solution. The mixture was heated to 70°C for four hours so that all of the ethanol in the blood sample was oxidized to acetic (ethanoic) acid. This reaction can be represented by the following equation:

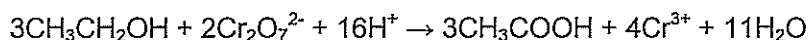

The volume of the mixture was made up to 150.0 mL by the addition of distilled water.

A titration was then done to find the amount of potassium dichromate left after the reaction. 30.00 mL aliquots of the reaction mixture were titrated against a 0.04104 mol L⁻¹ solution of iron (II) sulfate.

- (a) Write an equation for the reaction between potassium dichromate solution and the iron(II) sulfate solution. [2 marks]
- (b) The following titration results were obtained. Complete the table.

	1	2	3	4
Final volume (mL)	17.56	33.50	18.53	34.43
Initial volume (mL)	0.50	17.56	2.55	18.53
Titre				

- (c) Calculate the concentration of ethanol in the blood in (i) mol L⁻¹ and (ii) g L⁻¹ [1 mark]
- (d) The legal limit for ethanol in the blood is 50 mg per 100 mL of blood. Was this blood sample under or over the limit? (You must show reasoning). [8 marks]

[2 marks]

2004 Part 1

7. 100 g of mineral water was found to contain 0.00584 g of NaCl. What is the concentration of NaCl in parts per million by mass?
- e) 1.00
f) 5.84
g) 58.4
h) 584
10. What is the concentration of a Ba(OH)₂ solution that has a pH of 9.30?
- (a) $1.00 \times 10^{-5} \text{ mol L}^{-1}$
(b) $2.00 \times 10^{-5} \text{ mol L}^{-1}$
(c) $2.50 \times 10^{-10} \text{ mol L}^{-1}$
(d) $5.01 \times 10^{-10} \text{ mol L}^{-1}$
12. 20.0 mL of a 0.0100 mol L⁻¹ solution of NaOH is added to 20.0 mL of a 0.0300 mol L⁻¹ solution of NaCl. What is the pH of the resulting solution?
- (a) 2.00
(b) 7.00
(c) 11.70
(d) 12.00
13. Which one of the following equations does not represent the donation and acceptance of protons?
- (a) $2\text{H}^+ + 2\text{e}^- \rightarrow \text{H}_2$
(b) $\text{H}^+ + \text{OH}^- \rightarrow \text{H}_2\text{O}$
(c) $\text{H}_2\text{O}_2 + \text{OH}^- \rightarrow \text{HO}_2^- + \text{H}_2\text{O}$
(d) $\text{H}_2\text{C}_2\text{O}_4 + \text{CO}_3^{2-} \rightarrow \text{HC}_2\text{O}_4^- + \text{HCO}_3^-$
16. Ionisation of acetic (ethanoic) acid can be represented by the following equation
 $\text{CH}_3\text{COOH}(\text{aq}) + \text{H}_2\text{O}(\text{l}) \rightarrow \text{CH}_3\text{COO}^-(\text{aq}) + \text{H}_3\text{O}^+(\text{aq})$
Which one of the following would increase the concentration of acetate ions?
- (a) addition of a strong base
(b) addition of a strong acid
(c) addition of a weak acid
(d) dilution with water
17. Solid sodium acetate is added to water. Which one of the following statements best describes what happens?
- (a) The pH decreases because the acetate ions react with water to produce acetic acid.
(b) The pH decreases because the sodium ions react with water to produce hydrogen ions.
(c) The pH increases because the acetate ions react with water to produce hydroxide ions.
(d) The pH increases because the sodium ions react with water to produce hydroxide ions.
18. Ammonia is classified as a weak electrolyte. Which of the following statements best explains this?
- (a) A water-solution of ammonia contains more hydroxide ions than hydrogen ions.
(b) Ammonia is very soluble in water.
(c) Hydrogen bonding exists between ammonia molecules.
(d) In a water-solution only some of the ammonia molecules have reacted with water molecules.

2004 Part 2

6. When concentrated sulfuric acid needs to be diluted, should water be added to it or should it be added to water? Explain your answer.
- [2 marks]
9. Sodium carbonate is used as a primary standard in acid-base titrations, while sodium hydroxide is not. Explain why this is so.

[4 marks]

2004 Part 3

2. Borax, $\text{Na}_2\text{B}_4\text{O}_7 \cdot 10\text{H}_2\text{O}$, can be used as a primary standard in acid-base titrations. It reacts according to the following equation:

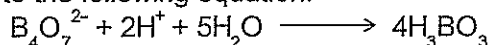

2.334 g of borax was dissolved in a 250.0 mL volumetric flask and the flask filled to the mark with distilled water. 20.00 mL aliquots of the borax solution were titrated against a hydrochloric acid solution and the following results were obtained.

	1	2	3	4
Final reading (mL)	20.20	36.80	21.07	37.70
Initial reading (mL)	2.55	20.20	4.35	21.07
Titration volume (mL)				

Calculate the concentration of the hydrochloric acid solution.

[9 marks]

2005 Part 1

9. What is the pH of a $5.0 \times 10^{-3} \text{ mol L}^{-1}$ solution of barium hydroxide?
 1) 2
 2) 2.3
 3) 11.7
 4) 12
10. The water in a seriously neglected swimming pool is tested and found to have a pH of 3. By what factor must the hydrogen ion concentration be changed to increase the water pH to 6?
 (a) decrease the hydrogen ion concentration by 1000 times;
 (b) double the hydrogen ion concentration;
 (c) halve the hydrogen ion concentration;
 (d) increase the hydrogen ion concentration by 1000 times.
13. Which one of the following correctly identifies the acidity, basicity or neutrality of each of the given solutions?
- | | Sodium hydrogensulfate | Potassium phosphate | Ammonium chloride | Magnesium nitrate |
|-----|------------------------|---------------------|-------------------|-------------------|
| (a) | Acidic | Acidic | Acidic | Basic |
| (b) | Neutral | Basic | Neutral | Acidic |
| (c) | Acidic | Basic | Acidic | Neutral |
| (d) | Basic | Neutral | Basic | Neutral |
29. In a sample of ground water, iron in the form of Fe^{2+} was found to have a concentration of $9.00 \times 10^{-3} \text{ mol L}^{-1}$. Assuming the density of the water sample is 1.00 g mL^{-1} , what is the concentration of Fe^{2+} expressed in ppm?
 (a) 0.502 ppm
 (b) 9.00 ppm
 (c) 50.2 ppm
 (d) 502 ppm

2005 Part 3

5. (a) A hydrochloric acid solution was standardised by titrating 10.00 mL of it against a 0.106 mol L^{-1} sodium hydroxide solution. The following results were obtained.

Volume of Sodium Hydroxide Solution

	TITRATION			
	1	2	3	4
Final volume (mL)	37.56	37.18	38.53	37.27
Initial volume (mL)	0.50	1.22	2.55	1.33
Titre				

- (a) Calculate the concentration of the hydrochloric acid solution.
- (b) A sample of magnesium oxide was found to be contaminated with sodium chloride. Magnesium oxide is not very soluble in water but can be dissolved in an excess of the standardised hydrochloric acid. In order to determine the purity of the magnesium oxide, 3.86 g of the sample was dissolved in 500.0 mL of hydrochloric acid solution and then 50.0 mL of the resulting solution was titrated against the sodium hydroxide solution of known concentration. The average titre was found to be 10.4 mL.
- (c) Calculate the percentage of magnesium oxide in the contaminated sample.

[12 marks]

2006 Part 1

11. Methyl violet produces the following colours when added to solutions of known pH.

pH	Colour
0	Yellow
1	Green
2	Violet
3	Violet

Methyl violet is added to 1.0 mol L⁻¹ solutions of hydrochloric acid, acetic (ethanoic) acid and nitric acid. Which one of the following correctly identifies the colours the indicator will produce in each solution?

	Hydrochloric acid	Acetic acid	Nitric acid
(a)	Yellow	Yellow	Yellow
(b)	Yellow	Violet	Green
(c)	Green	Green	Green
(d)	Yellow	Violet	Yellow

12. Which one of the following correctly identifies the acidity of the listed salts when dissolved in water?

	Potassium chloride	Sodium nitrate	Ammonium sulfate	Sodium carbonate
(a)	Neutral	Acidic	Acidic	Neutral
(b)	Acidic	Acidic	Basic	Acidic
(c)	Neutral	Neutral	Acidic	Basic
(d)	Acidic	Neutral	Neutral	Basic

2006 Part 2

11. (a) Write the equation for ammonium nitrate dissolving in water.
- (b) Given that the reaction is endothermic, describe what you would observe when solid ammonium nitrate is dissolved in a beaker of water.
- (c) Draw an energy profile diagram to represent this reaction. On your diagram you should include and label the following:
- Activation energy
 - ΔH
 - Transition state.

[6 marks]

12. Briefly explain why methyl orange (end point 4-5) is an inappropriate indicator to use in a titration between sodium hydroxide and acetic (ethanoic) acid.

2006 Part 3

5. The amount of ethanol in wine can be determined by adding a known excess volume of potassium permanganate to the wine and then titrating the left-over KMnO_4 with oxalic acid.

100.0 mL of 0.255 mol L⁻¹ KMnO_4 solution was added to 8.00 mL of white wine and made up to 250.0 mL with distilled water. 20.0 mL samples of the treated wine were then titrated with a 0.0504 mol L⁻¹ solution of oxalic acid dihydrate ($\text{C}_2\text{H}_2\text{O}_4 \cdot 2\text{H}_2\text{O}$).

The following results were obtained.

Titration results	Trials			
	1	2	3	4
Final volume	29.4	26.45	27.30	24.60
Initial volume	2.6	3.20	4.35	1.50
Titre				

The relevant equations are given below:

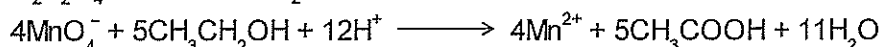
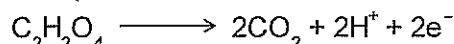
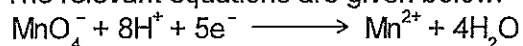

- (a) Write a balanced equation for the reaction between potassium permanganate and oxalic acid. Using the equations provided:
- (b) Determine the concentration of ethanol in the original wine in mol L⁻¹
- (c) Determine the concentration of ethanol in the wine in g L⁻¹.

[11 marks]

2007 Part 1

10. Consider the following acid-base reaction

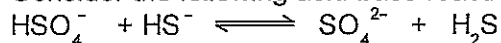

Which one of the following correctly identifies the acid-base conjugate pairs in this system?

	Acid	Conjugate Base	Base	Conjugate Acid
(a)	HSO ₄ ⁻	HS ⁻	SO ₄ ²⁻	H ₂ S
(b)	HSO ₄ ⁻	SO ₄ ²⁻	HS ⁻	H ₂ S
(c)	HSO ₄ ⁻	H ₂ S	HS ⁻	SO ₄ ²⁻
(d)	HS ⁻	HSO ₄ ⁻	H ₂ S	SO ₄ ²⁻

11. Which one of the following solutions would have a pH of 10?

- (a) 1 × 10⁻¹⁰ mol L⁻¹ sodium hydroxide
 (b) 5 × 10⁻⁵ mol L⁻¹ barium hydroxide
 (c) 1 × 10⁻⁴ mol L⁻¹ calcium hydroxide
 (d) 1 × 10⁻¹⁰ mol L⁻¹ nitric acid

12. Which one of the following statements is true?

- (a) Only organic acids are weak.
 (b) H₂O and OH⁻ are a conjugate acid-base pair.
 (c) Weak acid solutions do not contain H₃O⁺.
 (d) Diluting a strong acid produces a weak acid.

2007 Part 3

3. Ascorbic acid, C₆H₈O₆, is known as vitamin C. The vitamin C content in vitamin C tablets can be determined by adding a known excess volume of iodine solution to an aqueous solution of the vitamin C tablet. The remaining iodine can then be titrated with sodium thiosulfate (Na₂S₂O₃). A researcher analysing the vitamin C in a particular brand of tablets carried out the following steps: A 250 mg (2.50 × 10⁻¹ g) tablet was dissolved in 50.0 mL of water, and 100.0 mL of 0.0521 mol L⁻¹ I₂ solution was added. This mixture was then made up to 250.0 mL with water in a volumetric flask. 20.0 mL aliquots of the resulting solution were titrated with 0.0493 mol L⁻¹ sodium thiosulfate solution (Na₂S₂O₃)

The following results were obtained:

Titration Results	Trials (mL)			
	1	2	3	4
Final Volume	15.27	15.92	14.28	15.67
Initial volume	0.42	1.96	0.50	1.75
Titre				

The relevant half-equations are:

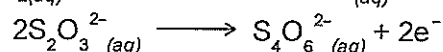
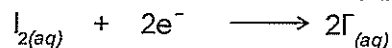
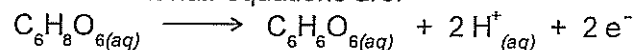

- Write and balance the equation for the reaction between iodine and thiosulfate ions.
- Write a balanced equation for the reaction between ascorbic acid (vitamin C) and iodine.
- Calculate the mass of vitamin C in the 250 mg tablet.
- Calculate the percentage by mass of vitamin C in the tablet.

[11 marks]

2008 Part 1

10. Which of the following statements about aqueous solutions of weak acids is true?
- A weak acid is a concentrated acid that has been diluted.
 - A 1.00 mol L⁻¹ solution of a weak acid contains more molecules of acid than ions.
 - Less than 1.0 mol of sodium hydroxide is required to react completely with 1.0 mol of a monoprotic weak acid.
 - The salt produced through the neutralisation of a weak acid by a strong base is slightly acidic.

11. Which of the following classifications is correct?

	KCl	KCH ₃ COO	NH ₄ Cl	KHSO ₄
(a)	Neutral	Basic	Acidic	Acidic
(b)	Neutral	Basic	Acidic	Neutral
(c)	Acidic	Acidic	Basic	Basic
(d)	Neutral	Acidic	Basic	Acidic

12. In a titration a student
- Washed the burette with distilled water and a small quantity of acid before filling with acid.
 - Washed the pipette with distilled water before filling with base.
 - Washed the conical flasks with distilled water and a small quantity of base before adding the base from the pipette.
 - Rinsed the sides of the conical flasks with distilled water during the titrations.
 - Added two drops of indicator to each conical flask

The students found they could not obtain consistent results. Which of the above steps could have been responsible for the errors?

- I and V only
 - II and III only
 - II, III and IV only
 - I, II and IV only
13. In which of the following reactions is the underlined species acting as a base?
- CH₃NH₂ + CH₃CH₂COOH → CH₃NH₃⁺ + CH₃CH₂COO⁻
 - NH₄⁺ + SO₄²⁻ → NH₃ + HSO₄⁻
 - NH₃ + H₂O → NH₂⁻ + H₃O⁺
 - 2CrO₄²⁻ + 2H₂SO₄ → Cr₂O₇²⁻ + H₂O + SO₄²⁻

14. An indicator and the pH range in which it changes colour are given below.

Indicator	pH range for colour change (lower to higher pH)	Colour change
-----------	--	---------------

Methyl green	1.0...3.1	Yellow to blue
--------------	-----------	----------------

For each of the following 1.00 mol L⁻¹ solutions, which set of indicator colours for methyl green is correct?

	Hydrochloric acid	Nitric acid	Acetic acid	Sodium hydroxide
(a)	Yellow	Yellow	Blue	Blue
(b)	Yellow	Blue	Blue	Yellow
(c)	Yellow	Blue	Blue	Blue
(d)	Yellow	Blue	Yellow	Blue

Use the following information to answer Questions 25 and 26. A student has 20.0 mL of 0.15 mol L⁻¹ Ba(OH)₂ solution and 30.0 mL of 0.223 mol L⁻¹ HCl solution.

25. What is the pH of the Ba(OH)₂ solution?
- (a) 0.52
(b) 2.52
(c) 13.18
(d) 13.48
26. If the two solutions are mixed, what is the pH of the resulting solution?
- (a) 1.13
(b) 1.86
(c) 2.43
(d) 3.16

2008 Part 2

Question 9

A student was given a 0.100 mol L⁻¹ sulfuric acid solution and a 0.200 mol L⁻¹ hydrochloric acid solution. She tested the pH of the solutions using a pH meter and found that the pH of the sulfuric acid solution was higher than that of the hydrochloric acid solution. Explain this observation. Include equations in your answer.

2008 Part 3

3. A bottle of anhydrous oxalic acid (H₂C₂O₄) was found to be contaminated with potassium chloride. 2.05 g of the mixture was dissolved in distilled water and the volume made up to 250.0 mL in a volumetric flask. 20.0 mL aliquots of the solution were titrated against 0.115 mol L⁻¹ sodium hydroxide solution and the following results were obtained:

Titration Results	Trials (mL)			
	1	2	3	4
Final Volume	32.05	32.10	31.11	33.25
Initial volume	0.50	2.45	1.40	3.65
Titre				

- (a) Write an equation for the reaction between oxalic acid and sodium hydroxide.
(b) Complete the table.
(c) Calculate the average titre.
(d) Calculate the concentration of the oxalic acid solution.
(e) Calculate the percentage purity of the oxalic acid mixture.

2009 Part 1

14. Which one of the following statements best explains why water is classified as a weak electrolyte?
- A strong acid or strong base is required to ionise water molecules.
 - The rate of ionisation of water molecules is very slow.
 - When water ionises, the concentration of $\text{OH}^-(\text{aq})$ is equal to the concentration of $\text{H}^+(\text{aq})$.
 - A small proportion of the water molecules will form $\text{H}^+(\text{aq})$ and $\text{OH}^-(\text{aq})$.
15. In which one of the following is water acting as a base?
- $\text{H}_2\text{O}(\text{l}) + \text{NH}_3(\text{aq}) \longrightarrow \text{NH}_4^+(\text{aq}) + \text{OH}^-(\text{aq})$
 - $\text{H}_2\text{O}(\text{l}) + \text{CO}_2(\text{g}) \longrightarrow \text{H}_2\text{CO}_3(\text{aq})$
 - $\text{H}_2\text{O}(\text{l}) + \text{HSO}_4^-(\text{aq}) \longrightarrow \text{H}_3\text{O}^+(\text{aq}) + \text{SO}_4^{2-}(\text{aq})$
 - $2\text{H}_2\text{O}(\text{l}) + 2\text{Na}(\text{s}) \longrightarrow 2\text{NaOH}(\text{aq}) + \text{H}_2(\text{g})$
17. The pH of a solution formed by adding 200 mL of distilled water to 20.0 mL of 2.00 mol L⁻¹ hydrochloric acid is
- 0.39.
 - 0.70.
 - 0.74.
 - 1.39.
18. Which one of the following could be described as a low concentration of a strong base?
- 3.00×10^{-3} mol L⁻¹ ammonia
 - 1.00×10^{-3} mol L⁻¹ calcium hydroxide
 - 1.00 mol L⁻¹ sodium hydroxide
 - 0.0200 mol L⁻¹ sodium carbonate
19. A 20.0 mL aliquot of 0.100 mol L⁻¹ sodium carbonate solution is titrated with hydrochloric acid with an approximate concentration of 0.1 mol L⁻¹ in the presence of methyl orange indicator. The colour for methyl orange over a range of pH values is given below.

pH	1 - 3.3	3.3 - 4.4	4.4 - 14
Colour	Red	orange	Yellow

Which one of the following describes what will be observed?

- The colour changes from yellow to orange after about 40 mL of the acid has been added.
 - The colour changes from yellow to orange after about 20 mL of the acid has been added.
 - The colour changes from yellow to red after about 20 mL of the acid has been added.
 - The colour changes from red to yellow after about 40 mL of the acid has been added.
- (d) The densities, in grams per millilitre, of the original antacid preparations are given below.
- | | |
|---------------------|-------------------------------|
| Suspension | Density (g mL ⁻¹) |
| Mg(OH) ₂ | 1.06 |
| Al(OH) ₃ | 1.12 |
- Calculate the concentration, in mg per mL, of Al(OH)₃ in the original Al(OH)₃ suspension. (7 marks)
 - From his titration of the Mg(OH)₂ diluted suspension, the student found the mass of Mg(OH)₂ in the 250 mL diluted suspension to be 1.13 g. Determine the concentration of Mg(OH)₂ in the original undiluted suspension and express your answer in mg per mL. (2 marks)
- (e) The directions for use on each of the antacid preparations suggest a standard adult dose of 10.0 mL. Which of the preparations would be more effective (neutralise the most HCl) per standard dose? Show your working. (4 marks)

The Acid Base Answers

1990 Part 1 Answers

6	(e)	9.	(a)	14	(e)	15	(d)
16	(e)	17	(c)				

CH₃COO⁻ is a weak base

The acidity of the NH₄⁺ ion counters the basicity of the CH₃COO⁻ ion. [Because K_a of NH₄⁺ and K_b of CH₃COO⁻ are very close]

2002 Part 1

20d 30d

2002 Part 3

5a 5.50 × 10⁻³ moles

5b 0.495 g

5c 1.63 tablets

5d 0.303 g per tablet

5e Yes

2003 Part 1

27 c 28 d 29 a

2003 Part 2

8 HCl is a strong acid which is fully ionised in aqueous solution, so [H₊(aq)] = [HCl]

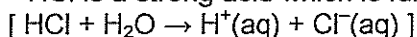

and pH = -log[H₊(aq)] = -log 1.0 × 10⁻³ = 3 [2 marks]

CH₃COOH is a weak acid, so only a small percentage is dissociated

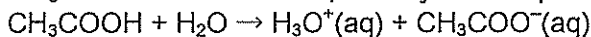

[H⁺(aq)] << [CH₃COOH] = 1.0 so the pH could be around 3. [2 marks]

2003 Part 3

5a 6 Fe²⁺(aq) + Cr₂O₇²⁻(aq) + 14 H⁺(aq) → 6 Fe³⁺(aq) + 2 Cr³⁺(aq) + 7 H₂O accept without states

5b Titre 17.06 15.94 15.98 15.90

5c 1.53 × 10⁻² mol L⁻¹ and 0.704 g L⁻¹

5d in 100 mL = 0.100 × 0.7042 = 0.07042 g = 70.42 mg which is over the legal limit of 50 mg per 100 mL.

2004 Part 1

7 c 10 a 12 c 13 a 16 a 17 c 18 d

2004 Part 2

6 Concentrated acid should be added to water [1 mark]

And one similar to the following:

Reaction very exothermic./ Adding water to acid can result in acid spitting out of beaker. / The water boils and spits / [1 mark]

Answers such "it is dangerous" are not acceptable.

9 Sodium carbonate is available with high purity, does not absorb water or react with CO₂ readily and has a high molar mass so can determine number of moles accurately. Sodium hydroxide absorbs water and reacts with CO₂, so difficult to know moles accurately. [4 points for 1 mark each]

2004 Part 3

2 0.0588 mol L⁻¹

2005 Part 1

9 d 10 a 13 c 29 d

2005 Part 3

5a 0.381 mol L⁻¹

5b 93.7%

2006 Part 1

11 d 12 c

2006 Part 2

11a (a) NH₄NO₃(s) → NH₄⁺(aq) + NO₃⁻(aq)

or

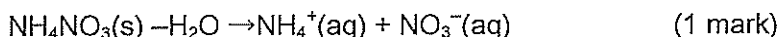

An equilibrium dissociation of the ammonium ion may be shown, but is not necessary. It is incorrect if shown as a one way arrow.

(b) The contents of the beaker become cooler. Condensation may appear on the outside of the beaker. (Only one is necessary) (1 mark)

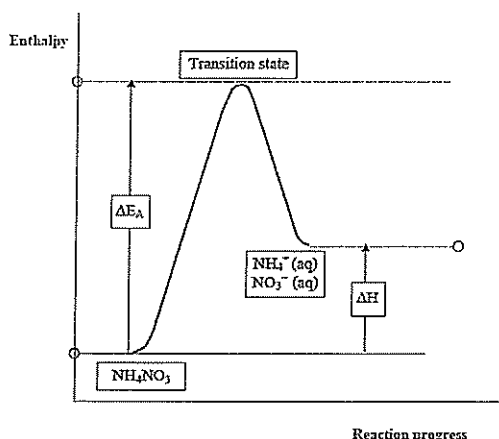

11c

12 The species at the equivalence point are Na^+ and acetate CH_3COO^- . Sodium ions do not react with water, but acetate is a weak base (the conjugate base of the weak acid, acetic acid)

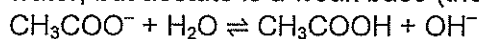

For this reason the pH is above 7 at the equivalence point. Methyl orange detects a pH change at pH 4-5, so it is unsuitable. [Phenolphthalein which changes colour at \sim pH 8 is suitable] (3 marks)

2006 Part 3

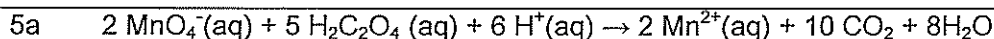

5b 3.075 mol L^{-1}

5c 141.7 g L^{-1}

2007 Part 1

10 b 11 b 12 b

2007 Part 3

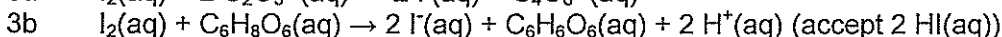
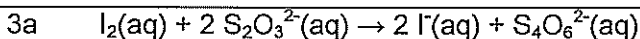

3c 0.1639 g

3d 65.6%

2008 Part 1

10 b 11 a 12 b 13 a 14 a 25 d 26 b

2008 Part 2

9 In $\text{HCl}(\text{aq})$ all of the molecules ionise, so that $[\text{H}^+] = 0.200 \text{ mol L}^{-1}$.

For H_2SO_4 , the first ionisation step

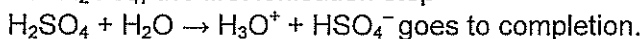

The second ionisation step

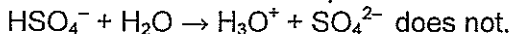

Therefore the $[\text{H}^+] \neq 2 \times 0.100$ or 0.200 mol L^{-1} , it will be less, giving a higher pH than the HCl solution.

1 mark

2008 Part 3

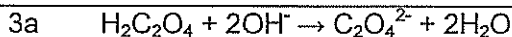

3b Titre 31.55 29.65 29.71 29.60

3c 29.7 (29.65) mL

3d $8.53 \times 10^{-2} \text{ mol L}^{-1}$

3e 93.6 %

2009 Part 1

14 d 15 c 17 c 18 b

Oxidation and reduction

Science Understanding

oxidation-reduction (redox) reactions involve the transfer of one or more electrons from one species to another

Summary of Redox

There must be one species oxidised and one reduced. The electrons cannot disappear!

Oxidation is

- gain of oxygen
- loss of hydrogen
- loss of electrons
- rise in oxidation number

Reduction is;

- loss of oxygen
- gain in hydrogen
- gain in electrons
- fall in oxidation number

oxidation involves the loss of electrons from a chemical species, and reduction involves the gain of electrons by a chemical species; these processes can be represented using half-equations and redox equations (acidic conditions only)

Balancing Half Equations

1. assign oxidation numbers
2. Balance the atoms/ions involved in the oxidation/reduction
3. balance the oxygens using water
4. Balance the charge by adding H^+
5. Balance the H^+ by adding e^- electrons
6. Check for charge balance

Balancing Redox Equations

1. Determine the half equations
2. Use coefficients to balance the electron transfer
3. add the two half equations
4. cancel if the same species appears on both sides and check for charge balance

the species being oxidised and reduced in a redox reaction can be identified using oxidation numbers

Oxidation Number is a system to assign numbers to keep track of electron shifts in molecules, ions and atoms

Rules for determining oxidation numbers

- The oxidation number of an element in the elemental state is zero
- The oxidation number of an atom in a monatomic ion is equal to the charge on the ion
- Certain atoms have the same oxidation number in all their compounds Gr I = +1, Gr II = +2, F = -1, O = -2 (except in peroxides -1 and $F_2O = +2$)
- The sum of the oxidation numbers of all atoms in a neutral atom is zero
- The sum of the oxidation numbers of all atoms in a polyatomic ion is equal to the charge on that ion

a range of reactions involve the oxidation of one species and reduction of another species, including metal and halogen displacement reactions, combustion and corrosion

a) reactions of metals with salts and acids

- Displacement of one metal from solution by another
- Activity Series: listing of common metals in order of decreasing strength as reductants.

Reducing strength decreases
K Na Ba Ca Mg Al Zn Fe Ni Sn Pb (H₂) Cu Ag Hg



- The activity series is the summary of experimental observations.
 - Metals which react with H_2O to form H_2 (K, Na, Ba, Ca) are strongest reductants.
 - Metals which react with dilute acids (but not with water) are placed next.
 - Those which do not react with H^+ (dilute acids), Cu, Ag, Hg, are least reactive metals.
- Displacement reactions are used to establish the sequence of these three sets of metals.
 - Hydrogen, though not a metal, is included in the sequence in order to separate those metals which will reduce hydrogen ions from those which will not.
 - In this series:
 1. metals to the left of hydrogen will react with dilute acids to form hydrogen gas.

2. a metal will reduce the cation of any metal to the right of it.
 3. the four most reactive metals will reduce water to hydrogen gas.
- Reactions of metals with hydrochloric and dilute sulfuric acids
 - Reactive metals such as magnesium, aluminium and iron, reduce the hydrogen ions of hydrochloric and dilute acids to hydrogen gas:

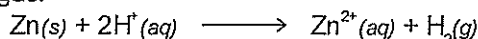

- In the activity series, metals to the left of hydrogen can reduce H^+ ions.
- Only in hydrochloric acid and in dilute sulfuric acid does the hydrogen ion oxidise these reactive metals. (In concentrated H_2SO_4 , SO_4^{2-} is a stronger oxidant than H^+)

b) reactions of halogens with halides

- Chlorine oxidises bromide to bromine, while bromine oxidises iodide to iodine.

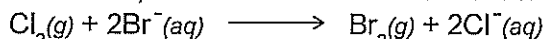

- Chlorine is a stronger oxidant than bromine, which is stronger than iodine.

Metals corrosion and galvanic protection of metals.

- Corrosion is the degradation of metal so that it loses strength and becomes unable to fulfil its intended purpose.
- Rust is hydrated iron oxide, $\text{Fe}_3\text{O}_2 \cdot x\text{H}_2\text{O}$, where x can vary from 0.5 to 2.
- The experimental facts about rust:
 1. Both oxygen and water are necessary for rust to form
 2. Salt water accelerates rusting
 3. Impure iron rusts more rapidly than pure iron
 4. Rust occurs most readily where iron is under mechanical stress - at bends in sheets
 5. Iron rusts more rapidly when attached to a less reactive metal such as copper or tin.
- From these facts, one can deduce that rust formation is an electrochemical process.

The common methods of rust prevention are:

1. Paint - stops oxygen and water coming into contact with the iron and so rust cannot form.
 - Disadvantage: if paint gets scratched or chipped, some iron becomes exposed & rust can creep along underneath the rest of the paint
2. Cover the iron with a thin coating of tin - tinsplating has the similar disadvantage to paint.
3. Galvanise the iron - cover the iron surface with a thin layer of a more reactive metal such as zinc.
 - Advantage: if zinc coating scratched, it still offers protection.
 - Even better protection is given by a coating with a mixture of zinc and aluminium.
 - Tinsplating is less effective because tin is less reactive than iron.
4. Use a sacrificial electrode - a block of zinc or magnesium attached to the hull of a ship or to the tank or pipeline.
5. Alloy the iron with chromium to make stainless steel - chromium readily forms an oxide which adheres very tightly to the metal and forms an impermeable layer.
6. Stainless steel is an alloy of iron with at least 12% chromium.
7. Stainless steel is very resistant to rusting, but has the disadvantage of expense.

'Corrosion' of aluminium: even though aluminium is more reactive than iron, by forming a non-permeable layer of aluminium oxide, further oxidation is prevented.

- However, if sodium chloride is present, a porous mixture of sodium chloride & aluminium oxide forms a permeable layer that leads to corrosion near coastlines.

the relative strength of oxidising and reducing agents can be determined by comparing standard electrode potentials, and can be used to predict reaction tendency

Standard hydrogen electrode : The standard hydrogen electrode is a redox electrode which forms the basis of the scale of oxidation-reduction potentials. The actual electrode potential of the hydrogen electrode is estimated to be $4.44 \pm 0.02 \text{ V}$ at 25°C , but its standard electrode potential is said to be zero at all temperatures so that it can be used for comparison with other electrodes. The hydrogen electrode is based on the following redox half cell:

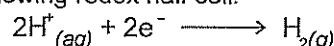

A standard hydrogen electrode consists of a platinum electrode in a solution containing H^+ ions. The solution (e.g. H_2SO_4) that contains the H^+ ions has a concentration of 1 mol/L. As the

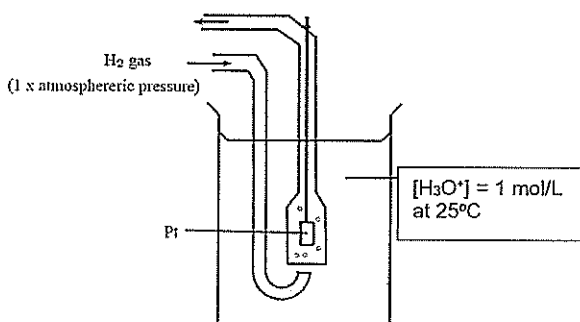

hydrogen gas bubbles over the platinum electrode, an equilibrium is set up between hydrogen molecules and hydrogen ions in solution. The reaction is as follows:

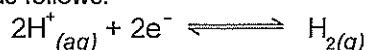

The position of this equilibrium can change if you change some of the conditions (e.g. concentration, temperature). It is therefore important that the conditions for the standard hydrogen electrode are standardised as follows: pressure = 100 kPa; temperature = 298 K (25°C) and concentration = 1 mol./L. In order to use the hydrogen electrode, it needs to be attached to the electrode system that you are investigating. For example, if you are trying to determine the electrode potential of copper, you will need to connect the copper half-cell to the hydrogen electrode; if you are trying to determine the electrode potential of zinc, you will need to connect the zinc half-cell to the hydrogen electrode and so on.

When copper is connected to the standard hydrogen electrode, relatively few electrons build up on the copper electrode. There are lots of electrons on the hydrogen electrode. [The hydrogen is more easily oxidised] By convention, the hydrogen electrode is written on the left hand side of the cell. The sign of the voltage tells you the sign of the metal electrode.

In the examples we used earlier, zinc's electrode potential is actually -0.76 and copper is +0.34. So, if a metal has a negative standard electrode potential, it means it forms ions more easily than hydrogen [it is more easily oxidised = a better reductant] The more negative the value, the easier it is for that metal to form ions [a better reducing agent]. If a metal has a positive standard electrode potential, it means it does not form ions easily.

- Metals at the top of series (e.g. Li) have more negative values. This means they ionise easily, in other words, they release electrons easily. These metals are easily oxidised and are therefore good reducing agents.
- Metal ions at the bottom of the table are good at picking up electrons. They are easily reduced and are therefore good oxidising agents.
- The reducing ability (i.e. the ability to act as a reducing agent) of the metals in the table increases as you move up in the table.
- The oxidising ability of metals increases as you move down in the table.

electrochemical cells, including galvanic and electrolytic cells, consist of oxidation and reduction half-reactions connected via an external circuit through which electrons move from the anode (oxidation reaction) to the cathode (reduction reaction)

Galvanic cells)

- Redox reactions involve transfer of electrons from one reactant to another.
- Redox reactions generating electricity: arrange for oxidation and reduction half reactions to occur at different locations, and by providing a wire for the electrons to flow through.
- A salt bridge is used to make electrical contact between two solutions.

Galvanic cell a device which makes a normal chemical reaction occur in such a way that it generates electricity.

- **Electrodes:** conductors of a cell which are connected to the external circuit.
- chemical reactions occurring at electrode called electrode processes / reactions.
- The purpose of the salt bridge is to allow the migration of ions to occur.
- When galvanic cell produces electricity, several distinct processes can be recognised.
 1. One electrode reaction liberates electrons which flow up the metallic conductor.
 2. These electrons flow through metallic conductor of the external circuit to other electrode.
 3. The reaction at the other electrode consumes these electrons.
 4. Ions migrate through solutions & salt bridge to maintain electrical neutrality.

Cell diagrams:

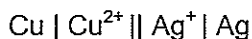

- Read as: "copper metal electrode in a solution containing copper ions. Solution connected by a salt bridge to a solution containing silver ions with an electrode of silver metal.

Anode and Cathode

- Anode is where oxidation occurs, cathode is electrode at which reduction occurs.
- In a galvanic cell, the anode is the -ve terminal while the cathode is the +ve terminal.
- predictions relating to particular redox reactions can be made using information on the relative ease of reduction or oxidation (or Reduction Potential Table).
 - The **electromotive force** or **EMF** of a galvanic cell is the potential difference (voltage) across the electrodes of the cell when a negligibly small current is being drawn. It is the maximum voltage that the cell can deliver.

- The standard electrode potential, E^0 , of an electrode is the potential of that electrode in its standard state relative to the standard hydrogen electrode.

galvanic cells produce an electric current from a spontaneous redox reaction

the electric potential difference of a cell under standard conditions can be calculated from standard electrode potentials; these values can be used to compare the voltages generated by cells constructed from different materials

electrochemical cells can be described in terms of the reactions occurring at the anode and cathode, the role of the electrolyte, salt bridge (galvanic cell), ion migration, and electron flow in the external circuit

cell diagrams can be used to represent electrochemical cells

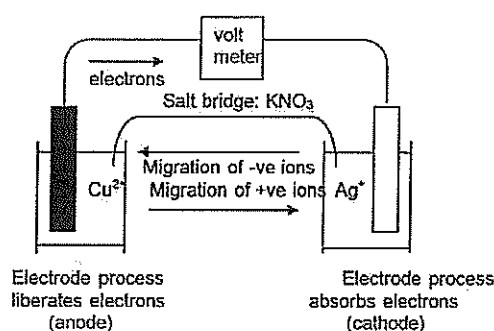

electrolytic cells use an external electrical potential difference to provide the energy to allow a non-spontaneous redox reaction to occur; electrolytic cells are used in a range of industrial situations, including metal plating and the purification of copper

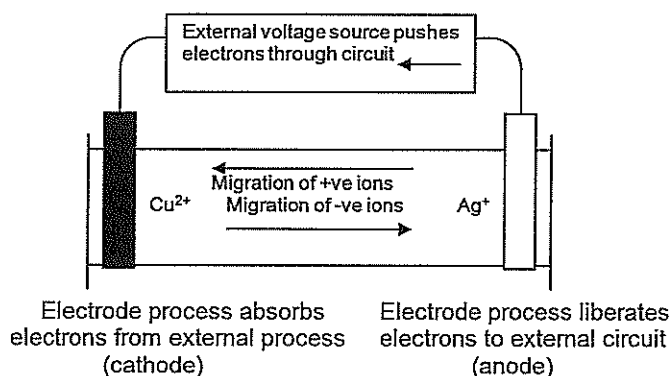

Electrolysis: is the process in which an electric current is used to bring about a chemical reaction which does not occur simultaneously.

- Copper and silver ions are reduced in preference to hydrogen ions, but hydrogen ions will be reduced in preference to most other metals.
- Br^- & I^- are always oxidised; NO_3^- & SO_4^{2-} are never oxidised
- Cl^- is oxidised if it is relatively concentrated. If it is dilute, H_2O is oxidised instead.

Science as a Human Endeavour

Spontaneous redox reactions can be used as a source of electrical energy, including primary, secondary and fuel cells. Fuel cells are a potential lower-emission alternative to the internal combustion engine and are already being used to power various modes of transport. Organisations, including the International

Partnership for Hydrogen and Fuel Cells in the Economy, have been created to foster global cooperation on research and development, common codes and standards, and information sharing on infrastructure development.

Hydrogen and Fuel Cells – A Global Opportunity

Hydrogen and fuel cell technologies are not yet fully competitive in the energy system. To increase their cost effectiveness, technology advancement is necessary. Around the world, Governments are strongly pursuing hydrogen and fuel cell technologies, collectively investing approximately \$1 Billion per year in RD&D activities. Centres of excellence designed to further develop hydrogen and fuel cell technologies in all IPHE countries are well established and making significant progress. Major automotive companies see commercialization starting in 2015, but government support for market introduction will be needed.

IPHE recommends the following actions by public and private sectors to further capitalize on the energy security and emissions-reductions benefits that the widespread adoption of hydrogen and fuel cell technologies offer:

- 1) Stimulating early markets through government procurement and early deployment and making available incentive programs for early adopters;
- 2) Continuing to improve product performance and cost-effectiveness through sustained investment in RD&D and infrastructure;
- 3) Expanding the use of variable renewable energy production through the integration of hydrogen and fuel cell technologies;
- 4) Motivating private and public sector financial investments in hydrogen and fuel cell technology developers and manufacturers; and
- 5) Improving education/public outreach, skills and training; codes, standards and regulations.

there are three types of galvanic cell in everyday use:

1. Primary Cells: Use-once-only cells: cells which cannot be recharged.
2. Secondary Cells : That have no power initially but are rechargeable cells: when flat, can be recharged by passing an electric current through them.
3. Fuel cells: as these cells discharge, some of the chemicals in them are used up, but the nature of the electrodes does not change. Can be recharged by adding more chemical (fuel) to them.

Primary Cells : Some commercial galvanic cell examples-do not learn them

The 'ordinary' dry cell.

- This is the most common and the cheapest of the commercially available cells.
- It is widely used in torches, radios and calculators.
- The cell diagram is:



- It consists of a zinc outer casing which is the negative electrode, an aqueous paste of ammonium chloride, and a mixture of powdered carbon and manganese dioxide around a carbon rod which is the positive terminal.
- Initially no zinc chloride is present, but as the cell is used zinc ions are formed and ammonium ions are discharged.
- At the negative terminal, the half reaction is:

$$\text{Zn} \rightarrow \text{Zn}^{2+} + 2\text{e}^-$$
- At the carbon rod, the half reaction is:

$$2 \text{NH}_4^+ + 2 \text{MnO}_2 + 2\text{e}^- \rightarrow \text{Mn}_2\text{O}_3 + 2 \text{NH}_3 + \text{H}_2\text{O}$$
- Manganese is reduced from an oxidation state of +4 to +3.
- This cell has a voltage of 1.5 volts.

Silver oxide cell

- The silver oxide cell is a 'button' cell.
- It is widely used in miniature appliances such as watches.
- Advantage: Quite small cells can provide considerable amounts of electricity at a very constant voltage over a long period of time.
- The conventional diagram for the cell is:

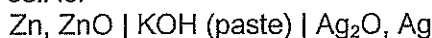

- The anode reaction is the same for the alkaline cell.
- The cathode reaction is:

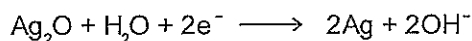

- Addition yields the overall reaction:

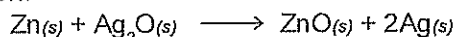

Secondary (Rechargeable) cells

nickel-cadmium:

- consists of a cadmium, cadmium hydroxide negative electrode and a nickel, nickel oxide, hydroxide positive pole, both in contact with a potassium hydroxide electrolyte:
$$\text{Cd, Cd(OH)}_2 \parallel \text{NiO}_2, \text{Ni(OH)}_2 \mid \text{Ni}$$
- cell has a voltage of 1.2V

lead accumulator or lead-acid battery:

- the common motor car battery:
$$\text{Pb} \mid \text{PbSO}_4 \parallel \text{PbO}_2 \mid \text{Pb}$$
- 12V car battery consists of 6 x 2V cells connected together in a series in the one outer casing.
- In order to obtain high current outputs from such batteries, surface area of electrode in contact with electrolyte has to be large, and +ve and -ve plates need to be close together.

Fuel cells

- **fuel cell** is a type of galvanic cell which can be recharged by adding more chemical (fuel) to it.
- The reason for the fuel cell to be able to operate indefinitely is that fuel cells operate without the electrodes undergoing any change in the electrode reactions.
- The **hydrogen-oxygen fuel cell** has electrodes of porous carbon, upon which a catalyst has been deposited. Hydrogen and oxygen flow slowly across the separate electrodes when there is a potassium hydroxide solution between the electrodes.
- Both hydrogen, which is the fuel, and oxygen, which is the oxidiser, have to be supplied continuously to the cell.
- The product, water, dilutes the KOH electrolyte which therefore has to be slowly replenished during operation.
- It is because the electrodes undergo no permanent chemical change during cell operation that the cell can be operated indefinitely by merely keeping up the supply of fuel & oxidiser.
- The big advantage of fuel cells is that they provide direct conversion of chemical energy to electrical energy and this can, in principle, be done with 80-100% efficiency.
- When we follow the route chemical energy to heat energy to mechanical energy to electrical energy, there are theoretical reasons why we can never get more than 35-40% conversion of chemical energy to electrical energy.

ATAR Chemistry

Unit 3: Redox

Twenty Years of TEE Unit 3

Questions

1990 - 2011

1990 Part 1

12. In which one of the following is the oxidation state of the underlined element -2?

- (a) $\underline{\text{N}}_2\text{H}_4$
- (b) $\underline{\text{N}}_2\text{O}_4$
- (c) $\text{Na}_2\underline{\text{S}}\text{O}_4$
- (d) $\text{Na}_2\underline{\text{S}}_2\text{O}_3$
- (e) $\text{Na}_2\underline{\text{Cr}}_2\text{O}_7$

1990 Part 2

11. Study the diagram below which shows a design for a hydrogen - chlorine fuel cell, then answer the questions which follow.

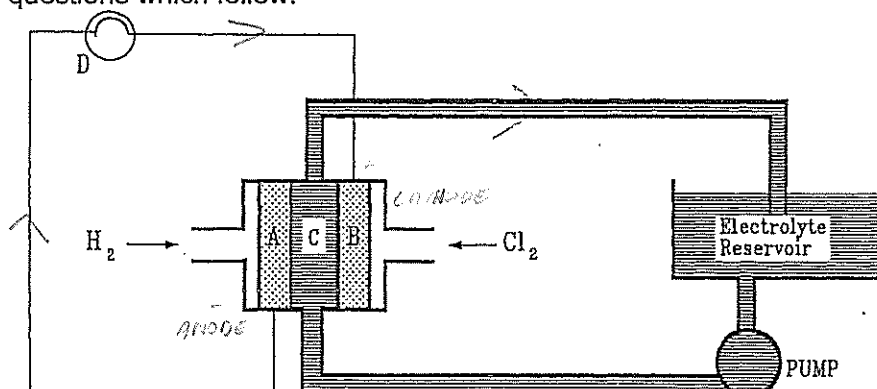

A and B are porous carbon electrodes containing catalysts.
C is hydrochloric acid which is circulated through the fuel cell by a pump.
The cell is discharged by connecting the electrodes by wires to a light bulb D.

- (a) What is the maximum cell voltage under standard conditions?
- (b) Write the chemical equation for the process occurring at electrode A.
- (c) Write the chemical equation for the process occurring at electrode B
- (d) write the name of the sole product synthesized by the fuel cell
- (e) draw an arrow on the diagram to show the direction of flow of the electrons in the wire

(2 ½ marks)

1991 Part 1

9. For the reaction:

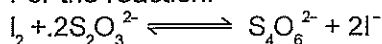

which one of the following statements is true?

- (a) The iodine is oxidised to iodide ion.
- (b) The iodine is the reductant.
- (c) The thiosulfate ion ($\text{S}_2\text{O}_3^{2-}$) is oxidised.
- (d) The thiosulfate ion ($\text{S}_2\text{O}_3^{2-}$) is reduced.
- (e) The thiosulfate disproportionates.



19. Use the following standard redox potentials to answer the question below

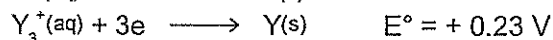
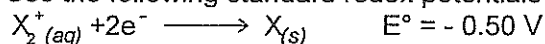

What is the standard redox potential of the following reaction?

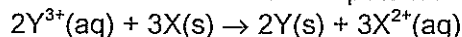

- (a) -0.27 V
 (b) +0.27 V
 (c) -0.73 V
 (d) +0.73 V
 (e) +1.96 V

$$3X \rightarrow 3X^{2+} + 2e^{-} = +0.50 + 0.23 = +0.73$$

21. Which of the following statements is correct about the cell illustrated below?

- (a) The electrons will flow from the magnesium to the zinc in the external circuit.
 (b) The magnesium electrode will gain weight.
 (c) The magnesium electrode is the cathode.
 (d) Zinc ions will move along the salt bridge to the magnesium half-cell.
 (e) The zinc electrode will lose weight.

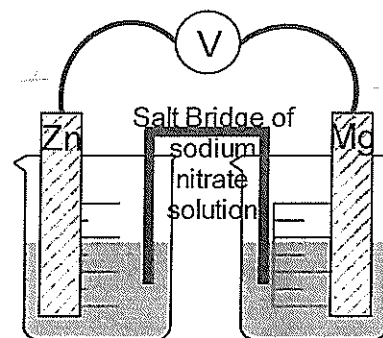

1 M zinc nitrate solution

1 M magnesium nitrate solution

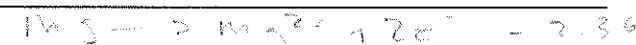
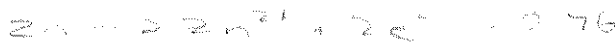

1991 Part 2

1. Give balanced equations for any reactions which occur in the following experiments. In each case describe observations such as colour changes, precipitate formation (give the colour), or gas evolution (give the colour or describe as colourless) resulting from the chemical reaction. Use ionic equations where appropriate.

(a) Chlorine is bubbled into a solution of potassium iodide.

(1 ½ marks)

9. An unpainted aluminium boat may be used in sea water, despite the fact that this relatively reactive metal is constantly exposed to salt water both inside and out.

(a) Explain why this aluminium object is not rapidly corroded.

(1 mark)

(b) The owner firmly fixed a fire extinguisher to the boat using steel bolts. Sometime later the extinguisher fell off because of corrosion. Give an explanation of this, based on chemical principles.

(2 marks)

1991 Part 3

3. 3.20 g of cast iron was dissolved in dilute sulfuric acid and the resulting solution made up to 100.0 mL with distilled water. 25.00 mL portions of this solution were then acidified further with dilute sulfuric acid and titrated against 0.101 mol L⁻¹ potassium permanganate solution. The volume of potassium permanganate solution needed to reach the end point was 26.45 mL.

Calculate the percentage by mass of iron in the cast iron. You may assume that none of the impurities in the cast iron react during the analysis. (5 marks)

1992 Part 1

16. Which one of the following conversions does not involve oxidation or reduction?

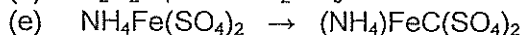
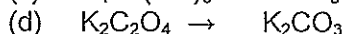
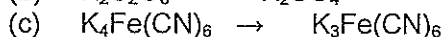
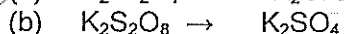
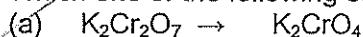

26. Which one of the following slows down the corrosion of a small strip of iron?

- (a) Placing the iron under stress.
- (b) Attaching a length of zinc to the iron. — **SACRIFICIAL PROTECT**
- (c) Attaching a length of copper to the iron.
- (d) Attaching a length of tin to the iron.
- (e) Storing the iron under water.

1992 Part 3

2. Two electrolysis cells are set up in series as shown in the diagram below. The electrodes are made of inert platinum.

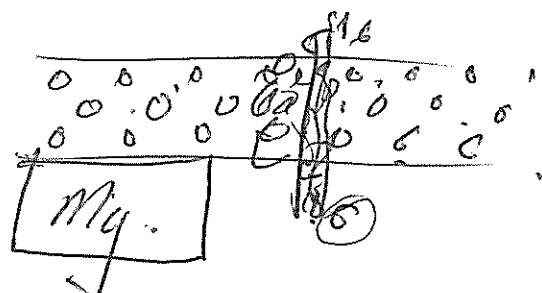
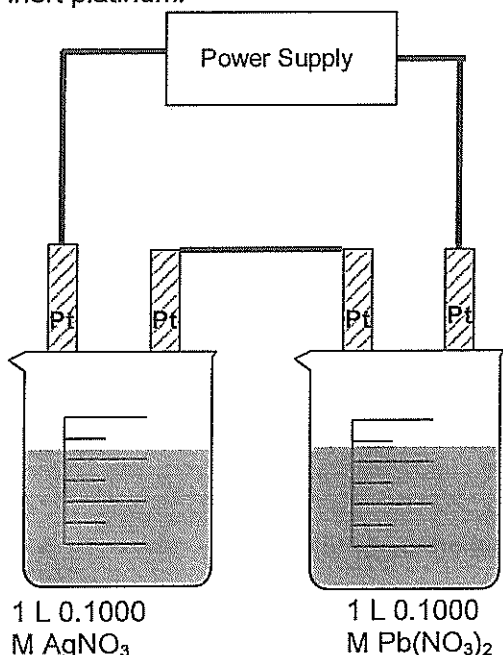

A low current is passed through the system for a time and then switched off. During the electrolysis 1.079 g of silver is deposited on the cathode in the left hand cell.

- (a) Calculate the mass of lead deposited on the cathode in the right hand cell during the electrolysis. [4 marks]
- (b) When the current is switched off, the contents of the right hand container are stirred.
 - (i) Calculate the concentration of lead ion in the 1.000 L of solution. [4 marks]
 - (ii) Calculate the concentration of nitrate ion in the solution. [1 mark]
- (c) Explain the relationship of the lead and nitrate ion concentrations you calculated in part (b). [1 mark]

8. Write two half equations and a balanced chemical equation for the reaction that occurs when a solution of potassium bromide (KBr) is treated with a solution containing potassium bromate (KBrO_3) and sulfuric acid to produce bromine (Br_2) [6 marks]

11. Below is a diagram of a simple electrochemical cell made using copper and zinc electrodes and solutions of copper sulfate and zinc sulfate. The salt bridge contains a saturated solution of potassium sulfate.

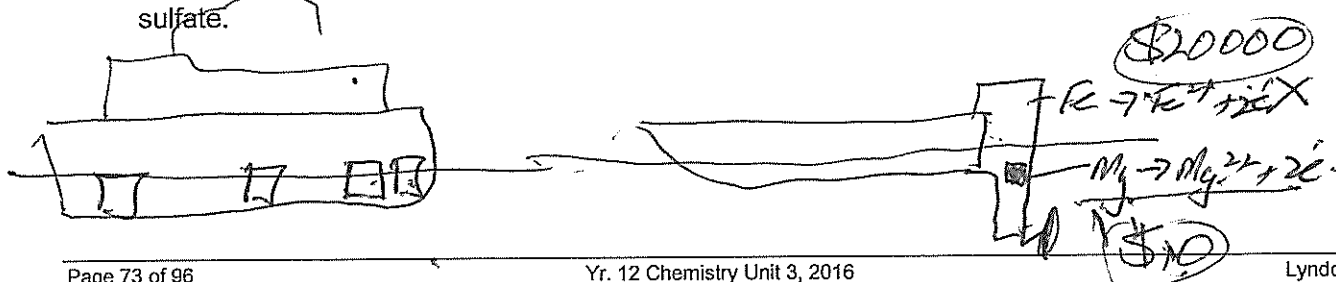

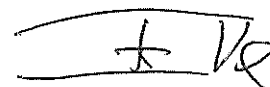
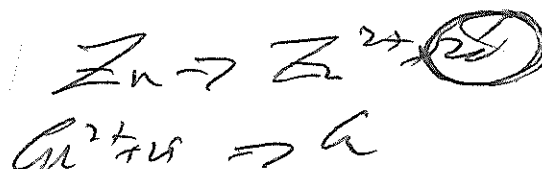
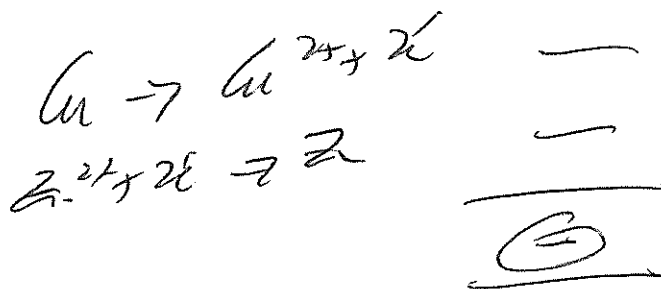
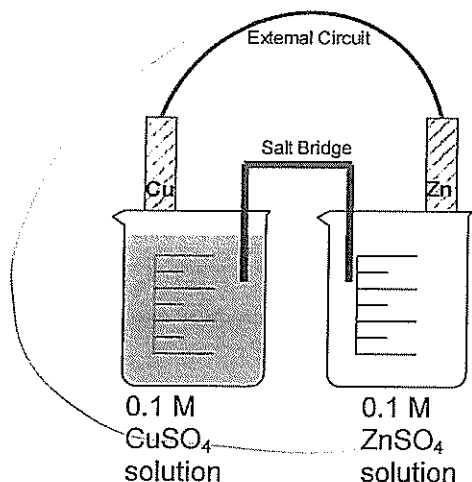

- (a) Which two chemical species are consumed when this cell is operated? [2 marks]
- (b) Draw an arrow on the external circuit to indicate the direction of the flow of electrons. [1 mark]
- (c) Write the formula of one ion that moves from the copper half-cell towards the zinc half-cell. [2 marks]
- (d) Write the formula of one ion that moves from the zinc half-cell towards the copper half-cell. [2 marks]
- (e) This type of cell was used to supply electricity for early telegraph stations. What two chemical substances (other than water) did the telegraph station manager have to purchase to maintain the operation of the cells? 2 marks

1993 Part 1

24. Which of the following can convert iron(II) ion in water solution to iron(III) ion?
- I Bromine dissolved in water⁷
- II Potassium chloride solution
- III Zinc lumps in dilute sulfuric acid
- IV A solution containing both potassium dichromate and sulfuric acid
- (a) I and III only
- (b) I and IV only
- (c) II and III only
- (d) II and IV only
- (e) III and IV only
25. When an electric current is passed through 1.0 mol L⁻¹ sodium chloride between graphite electrodes, which one of the following half-reactions occurs at the cathode?
- (a) $\text{Na}^+ + \text{e}^- \longrightarrow \text{Na}$
- (b) $2\text{H}_2\text{O} + 2\text{e}^- \longrightarrow \text{H}_2 + 2\text{OH}^-$
- (c) $2\text{Cl}^- \longrightarrow \text{Cl}_2 + 2\text{e}^-$
- (d) $2\text{H}_2\text{O} \longrightarrow \text{O}_2 + 4\text{H}^+ + 4\text{e}^-$
- (e) $\text{C} + 2\text{H}_2\text{O} \longrightarrow \text{CO}_2 + 4\text{H}^+ + 4\text{e}^-$

1993 Part 2

3. In the spaces provided, briefly state the chemical reason for each of the following observations.

Statement	Explanation
Although many metals react with acid, copper does not react significantly with dilute sulfuric acid	$E^{\ominus} \text{Cu}^{2+}/\text{Cu} > 0$
Although many metal carbonates react with acid, calcium carbonate does not react significantly with dilute sulfuric acid.	CaSO_4 coats CaCO_3

[4 marks]

14. Complete and label the following diagram of an operating Galvanic cell, which uses the metals copper and silver, soluble salts of these metals, and a potassium salt. You may also use any other standard laboratory equipment.

[2 marks]

On your diagram mark clearly

- the name or formula of the electrolyte in each beaker,
- each half equation,
- the direction of electron flow in the external circuit,
- the direction of anion flow in the cell.

[1 mark]

[2 marks]

[1 mark]

[1 mark]

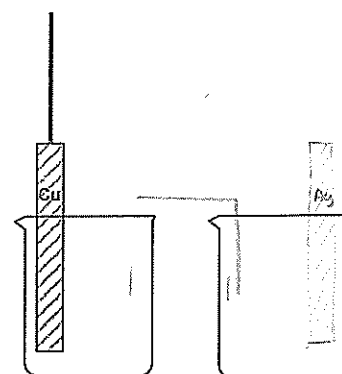

1994 Part 1

16. What is the oxidation number of bismuth (Bi) in magnesium bismuthate, $\text{Mg}(\text{BiO}_3)_2$?

- (a) I
- (b) II
- (c) III
- (d) IV
- (e) V

17. Which of the following is most likely to act as a reducing agent?

- (a) $\text{C}_2\text{O}_4^{2-}$
- (b) CH_3COO^-
- (c) ClO^-
- (d) Cu^{2+}
- (e) O_2

18. In which one of the following cases will an observable redox reaction take place when the two substances are mixed?

- (a) Tin(IV) chloride solution and potassium iodide solution
- (b) Potassium chloride solution and potassium iodide solution
- (c) Dilute sulfuric acid and mercury
- (d) Manganese(II) sulfate solution and zinc
- (e) Gold(III) nitrate solution and silver

1994 Part 2

12. The diagram below represents the industrial electrolysis process used to purify blister copper.

(a) What connects the points A and B in the external circuit?

[1 mark]

(b) Which way do the electrons flow between A and B in the external circuit? [1 mark]

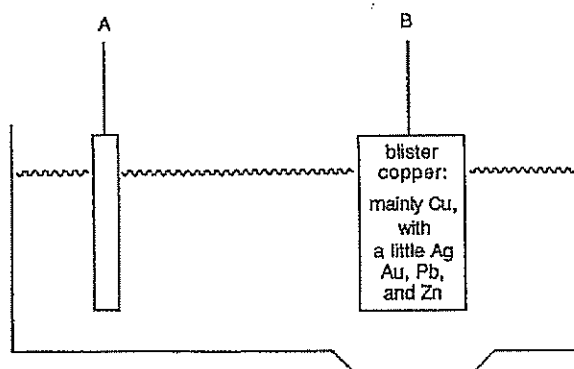

- (c) What is the electrolyte in the solution? [1 mark]
 (d) What happens to the copper in the blister copper? Where does it finish up? [2 marks]
 (e) What happens to the zinc in the blister copper? Where does it finish up? [2 marks]
 (f) What happens to the silver in the blister copper? Where does it finish up? [2 marks]

1995 Part 1

25. When an electric current is passed through 1.0 mol L⁻¹ sodium hydroxide between two platinum electrodes, which one of the following half-reactions occurs at the cathode?
 (a) $2\text{H}_2\text{O} \rightarrow \text{O}_2 + 4\text{H}^+ + 4\text{e}^-$
 (b) $4\text{OH}^- \rightarrow \text{O}_2 + 2\text{H}_2\text{O} + 4\text{e}^-$
 (c) $2\text{H}^+ + 2\text{e}^- \rightarrow \text{H}_2$
 (d) $2\text{H}_2\text{O} + 2\text{e}^- \rightarrow \text{H}_2 + 2\text{OH}^-$
 (e) $2\text{OH}^- + 2\text{e}^- \rightarrow \text{H}_2 + 2\text{O}^{2-}$

1996 Part 1

19. Standard Reduction Potentials for the iron(III)/iron(II) couple and the tin(IV)/tin(II) couple are given below, along with the colours of the ions.

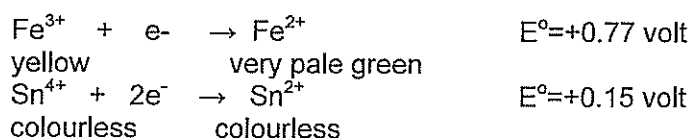

In which one of the following experiments would you observe a colour change?

- (a) Iron(II) chloride solution is added to tin(II) chloride solution.
 (b) Iron(II) chloride solution is added to tin(IV) chloride solution.
 (c) Iron(III) chloride solution is added to tin(II) chloride solution.
 (d) Iron(III) chloride solution is added to tin(IV) chloride solution.
 (e) In none of the experiments is a colour change observed.
20. One solution contains a titanium (Ti) salt, and a second solution contains a thallium (Tl) salt. When a quantity of electricity is passed through the two solutions as shown in the diagram below, 0.20 mol of Ti is deposited on one cathode and 0.40 mol of Tl on the other cathode.

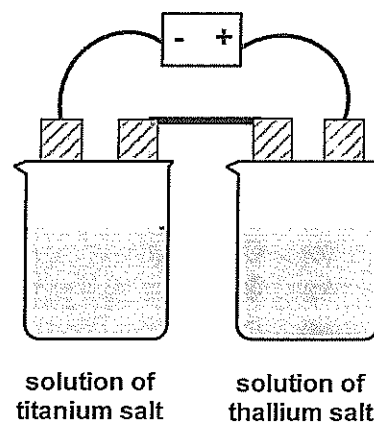

Which of the following conclusions can be drawn from these observations alone?

- I Both the Ti and the Tl ions are positively charged.
 II The charge on the Ti ion is double that on the Tl ion.
 III The Ti ion has a 2+ charge.
 IV The Tl ion has a 1+ charge.
- (a) I and II only
 (b) II only
 (c) II, III and IV only
 (d) All of I, II, III and IV
 (e) None of I, II, III and IV
29. Blister copper may contain iron, cobalt, nickel, zinc, silver, platinum and gold as impurities. When blister copper is refined by electrolysis, what happens to the cobalt and the platinum impurities?
- (a) Both the cobalt and the platinum finish up as ions in the electrolyte solution.
 (b) Both the cobalt and the platinum fall to the bottom of the electrolysis vessel as part of the anode mud.
 (c) Both the cobalt and the platinum remain in the blister copper anode which becomes increasingly impure.
 (d) The cobalt finishes up as Co^{2+} in the electrolyte solution and the platinum falls to the bottom.
 (e) The cobalt falls to the bottom and the platinum finishes up as Pt^{2+} in the electrolyte solution.

1996 Part 2

13. A student is asked to demonstrate that water is made from the elements hydrogen and oxygen. He decides to set up the following apparatus.

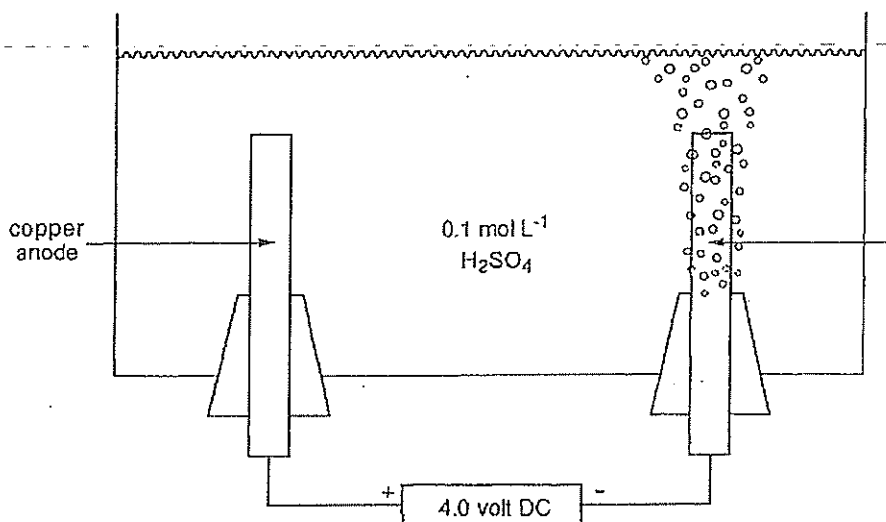

To his surprise a colourless gas is liberated from the cathode as expected, but no gas is liberated from the anode!

- Write the equation for the reaction occurring at the cathode.
- Write the equation for the reaction actually occurring at the anode. Describe how this anode reaction could be observed?
- How should the student modify the apparatus so that the intended demonstration is successful?
- Write the equation for the intended anode reaction.

1997 Part 1

- A dilute solution of lead nitrate is to be stored in a metal container. Which one of the following metals could be used?
 - aluminium
 - copper
 - iron
 - nickel
 - zinc
- A solution containing both copper(II) chloride and zinc chloride is made so that the concentration of each salt is 1 mol L^{-1} . What is the first product formed at the cathode when the solution is electrolysed using platinum electrodes?
 - chlorine
 - copper
 - hydrogen
 - oxygen
 - zinc

1997 Part 2

8. When a solution of potassium bromide (KBr) is added to a solution containing potassium bromate (KBrO_3) and sulfuric acid, the mixture turns orange which indicates that bromine is a reaction product. Work out the equation for the reaction that has occurred.

Oxidation half-equation	
Reduction half-equation	
Redox equation	

[5 marks]

9. Two test-tubes are labelled 'X' and 'Y' and each contains a colourless solution. A few drops of potassium dichromate solution are added to each tube, and the observations set out in the table below. In each case give the oxidation number of the chromium in the product, and suggest what each of the colourless solutions could be.

	Oxidation number of Cr in the product	Suggested original contents of test-tube
With test-tube 'X' the 'orange of the potassium dichromate' solution changes to Yellow		
With test-tube 'Y' the orange of the potassium dichromate solution changes to green		

[4 marks]

1998 Part 1

6. An element X has ions XO_3^{2-} and XO_4^{2-} . Which one of the following is X?
- chlorine
 - nitrogen
 - phosphorus
 - silicon
 - sulfur
21. A chromium-containing compound is reduced to chromium metal (in one or more steps). A total of 0.090 mole of electrons is involved in the reduction and 0.0150 mole of chromium metal is obtained. Which one of the following could have been the original compound?
- CrCl_2
 - CrCl_3
 - CrF_4
 - CrF_5
 - $\text{Na}_2\text{Cr}_2\text{O}_7$
28. Which one of the following statements is true?
- Galvanised iron will corrode rapidly if the zinc coating is scratched.
 - If a steel wharf is connected to the positive terminal of a lead accumulator this will help prevent corrosion of the wharf.*
 - If sodium chloride is used as an antifreeze in a car radiator, the radiator will corrode more rapidly than if 1,2-ethanediol is used.
 - The oxide layer on a piece of iron will prevent further corrosion by electrically insulating the iron.
 - Zinc can be used as a sacrificial anode to protect aluminium.

1998 Part 2

5. When dilute hydrogen peroxide is added to black manganese dioxide powder there is vigorous bubbling.
 What has happened to the hydrogen peroxide? [1 mark]
 What has happened to the manganese dioxide? [1 mark]
8. When a solution containing potassium dichromate ($\text{K}_2\text{Cr}_2\text{O}_7$) and sulfuric acid is added to a solution of tellurium(IV) oxide (TeO_2), the mixture turns deep green which indicates that chromium(III) ions are produced. Every reduction must be accompanied by oxidation, so the TeO_2 must have been oxidised. The only known higher oxidation state for Te is +6, so presumably an ion similar to SO_4^{2-} is produced. Work out the equation for the overall reaction that has occurred.

Oxidation half-equation :

Reduction half-equation :

Redox equation:

5 marks

1999 Part 1

12. Which one of the following statements about the salt bridge in an electrochemical cell is correct?
- Any soluble ionic compound can be used because its solution will be an electrical conductor.
 - A salt is chosen whose component ions are not readily oxidised or reduced.
 - Compounds containing highly charged positive ions such as Al^{3+} are not used because the highly charged ions tend to prevent electrons from flowing freely.
 - Salt bridges are made dilute so that anions and cations can move through them without excessive resistance.
18. Which one of the following species is the strongest reducing agent?
- Ar
 - Ca^{2+}
 - Cl^-
 - K^+
19. In which one of the following species does chlorine exhibit the highest oxidation number?
- Cl_2
 - Cl_2O
 - HClO_3
 - PCl_3

1999 Part 2

10. Here is a diagram of a Galvanic cell at 25 °C.

- Write the half-equation for the reaction occurring at the cathode. [2 marks]
- Draw an arrow on the diagram to illustrate the flow of electrons in the external circuit. [1 mark]
- What is the reading on the voltmeter? [2 marks]

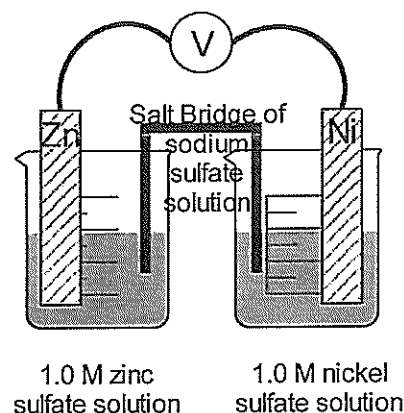

1999 Part 3

4. Sodium sulfite (Na_2SO_3) can be used as a preservative in hamburgers. In an experiment to determine the amount of Na_2SO_3 in a sample of hamburger, the following steps were followed.

Step 1: 1.00 kg of minced meat was boiled with an excess of dilute sulfuric acid.

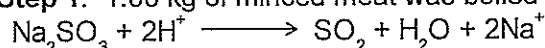

Step 2: The sulfur dioxide gas released was completely absorbed in an excess of sodium hydroxide solution.



Step 3: The resulting solution was acidified with excess dilute sulfuric acid and titrated with 0.02023 mol L^{-1} potassium permanganate. 30.08 mL of the potassium permanganate solution were required to reach the end-point.

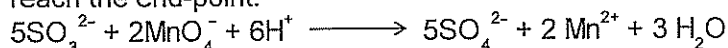

- (a) How many moles of SO_3^{2-} are required to react completely with 1 mole of MnO_4^- ? [2 marks]
- (b) Calculate the number of moles of Na_2SO_3 present in 1.00 kg of hamburger meat. [5 marks]
- (c) Government chemists often express the amount of Na_2SO_3 in meats as parts per million (ppm) [1 ppm = 1 mg Na_2SO_3 in 1 kg of meat]. Express the amount of Na_2SO_3 in the 1.00 kg meat sample in parts per million. [2 marks]
- (d) In step 1, why must the dilute sulfuric acid be in excess? [1 mark]
- (e) In step 3, what colour change in the reaction vessel would you observe at the end-point? [1 mark]

2000 Part 1

8. In which one of the following does hydrogen act as an oxidising agent?
- (a) $\text{C}_2\text{H}_4 + \text{H}_2 \rightarrow \text{C}_2\text{H}_6$
- (b) $\text{Cl}_2 + \text{H}_2 \rightarrow 2\text{HCl}$
- (c) $3\text{N}_2 + 2\text{H}_2 \rightarrow 2\text{NH}_3$
- (d) $2\text{Na} + \text{H}_2 \rightarrow 2\text{NaH}$
9. In which one of the following does the underlined element have an oxidation state of +5?
- (a) $\underline{\text{C}}\text{O}_3^{2-}$
- (b) $\underline{\text{Cl}}\text{O}_3^-$
- (c) $\underline{\text{Mn}}\text{O}_4^-$
- (d) $\underline{\text{S}}\text{O}_3^{2-}$
12. When an electric current is passed through 1 mol L^{-1} KI solution between two platinum electrodes, which one of the following half-reactions occurs at the anode?
- (a) $2\text{H}_2\text{O} \rightarrow \text{O}_2 + 4\text{H}^+ + 4\text{e}^-$
- (b) $2\text{I}^- \rightarrow \text{I}_2 + 2\text{e}^-$
- (c) $2\text{H}_2\text{O} + 2\text{e}^- \rightarrow \text{H}_2 + 2\text{OH}^-$
- (d) $\text{K}^+ + \text{e}^- \rightarrow \text{K}$
13. For the reaction described by the following equation: $\text{NH}_4^+ + \text{OH}^- \rightarrow \text{NH}_3 + \text{H}_2\text{O}$ which one of the following statements is correct?
- (a) NH_4^+ is behaving as an acid.
- (b) NH_4^+ is behaving as a base.
- (c) NH_4^+ is oxidised.
- (d) NH_4^+ is reduced.

2001 Part 1

Questions 13 and 14 are both about the following experiment.

An electric current is passed through a solution containing: 1 mol L^{-1} each of CuSO_4 , NaBr and KCl using two platinum electrodes.

13. Which one of the following species is produced at the anode?
- (a) $\text{Br}_2(\text{aq})$
- (b) $\text{Cl}_2(\text{g})$
- (c) $\text{Cu}(\text{s})$
- (d) $\text{O}_2(\text{g})$
14. Which one of the following species is produced at the cathode?
- (a) $\text{Cu}(\text{s})$
- (b) $\text{H}_2(\text{g})$
- (c) $\text{K}(\text{s})$
- (d) $\text{O}_2(\text{g})$

2002 Part 1

Questions 17 and 18 are both about the following experiment. An electric current is passed through a solution containing 1 mol L^{-1} each of MgSO_4 , KI and HCl , using two platinum electrodes.

17. Which one of the following species is produced at the anode?
- (a) $\text{Cl}_2(\text{g})$
 - (b) $\text{I}_2(\text{aq})$
 - (c) $\text{Mg}(\text{s})$
 - (d) $\text{O}_2(\text{g})$
18. Which one of the following species is produced at the cathode?
- (a) $\text{H}_2(\text{g})$
 - (b) $\text{I}_2(\text{aq})$
 - (c) $\text{K}(\text{s})$
 - (d) $\text{Mg}(\text{s})$
20. For the following equation
- $$2\text{H}_2\text{O}_2(\text{l}) \longrightarrow 2\text{H}_2\text{O}(\text{l}) + \text{O}_2(\text{g})$$
- which one of the following statements is true?
- (a) Hydrogen peroxide is acting as an acid.
 - (b) Hydrogen peroxide is acting as an acid and a base.
 - (c) Hydrogen peroxide is acting as an oxidising agent only.
 - (d) Hydrogen peroxide is acting as an oxidising and reducing agent.

2003 Part 1

15. Which one of the following arranges the substances in order of strongest to weakest reducing agent?
- (a) $\text{Cl}_2 > \text{Al}^{3+} > \text{Na}^+$
 - (b) $\text{Cl}_2 > \text{Si} > \text{Mg}$
 - (c) $\text{Mg} > \text{Al} > \text{Cl}^-$
 - (d) $\text{Na}^+ > \text{Al}^{3+} > \text{Cl}^-$
20. Using the standard reduction potential tables predict which one of the following reactions will possibly occur spontaneously.
- (a) $3\text{H}_2\text{O}_2 + 2\text{NO} \rightarrow 2\text{NO}_3^- + 2\text{H}_2\text{O} + 2\text{H}^+$
 - (b) $2\text{Fe}^{2+} + \text{O}_2 + 2\text{H}^+ \rightarrow 2\text{Fe}^{3+} + \text{H}_2\text{O}_2$
 - (c) $\text{Mg}^{2+} + \text{Zn} \rightarrow \text{Mg} + \text{Zn}^{2+}$
 - (d) $\text{Mn}^{2+} + 2\text{H}_2\text{O} + \text{Br}_2 \rightarrow \text{MnO}_2 + 4\text{H}^+ + 2\text{Br}^-$
21. Which one of the following equations does not represent an oxidation-reduction reaction?
- (a) $2\text{MnO}_4^- + 2\text{H}_2\text{O} + 3\text{C}_2\text{O}_4^{2-} \rightarrow 2\text{MnO}_2 + 6\text{CO}_3^{2-} + 4\text{H}^+$
 - (b) $\text{Cr}_2\text{O}_7^{2-} + \text{H}_2\text{O} \rightarrow 2\text{CrO}_4^{2-} + 2\text{H}^+$
 - (c) $2\text{Br}_2 + \text{N}_2\text{H}_5^+ \rightarrow \text{N}_2 + 5\text{H}^+ + 4\text{Br}^-$
 - (d) $6\text{I}^- + 14\text{H}^+ + \text{Cr}_2\text{O}_7^{2-} \rightarrow 3\text{I}_2 + 7\text{H}_2\text{O} + 2\text{Cr}^{3+}$
22. In which one of the following is the oxidation number of nitrogen lower than in any of the other substances listed?
- (a) $\text{Cu}(\text{NO}_3)_2$
 - (b) N_2
 - (c) N_2H_4
 - (d) NO_2
23. An electrochemical cell based on the following reaction has an $E^\circ = 1.03 \text{ V}$.
- $$\text{Cl}_2 + 2\text{V}^{3+} + 2\text{H}_2\text{O} \rightarrow 2\text{VO}^{2+} + 4\text{H}^+ + 2\text{Cl}^-$$
- What is the standard reduction potential for the reduction of VO^{2+} to V^{3+} ?

- (a) -3.05 V
- (b) -0.33 V
- (c) +0.33 V
- (d) +3.05 V

30. For the following equation



- (a) Hydrogen peroxide is acting as an acid.
- (b) Hydrogen peroxide is acting as an acid and a base.
- (c) Hydrogen peroxide is acting as an oxidising agent only.
- (d) Hydrogen peroxide is acting as an oxidising and reducing agent.

2003 Part 2

7. Consider the electrolysis of molten salt, $\text{NaCl}_{(l)}$, and of salt water, $1 \text{ mol L}^{-1} \text{NaCl}_{(aq)}$ with inert electrodes. Write the equations for the anode and cathode reactions for each case:

a. Molten $\text{NaCl}_{(l)}$,

anode:

cathode:

b. Solution $\text{NaCl}_{(aq)}$,

anode:

cathode:

[4 marks]

2003 Part 3

5. In a test to determine the level of alcohol in the blood of a motorist, 5.00 mL of blood was added to 100.0 mL of $0.005961 \text{ mol L}^{-1}$ acidified potassium dichromate solution. The mixture was heated to 70°C for four hours so that all of the ethanol in the blood sample was oxidized to acetic (ethanoic) acid. This reaction can be represented by the following equation:

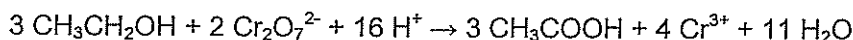

The volume of the mixture was made up to 150.0 mL by the addition of distilled water.

A titration was then done to find the amount of potassium dichromate left after the reaction. 30.00 mL aliquots of the reaction mixture were titrated against a $0.04104 \text{ mol L}^{-1}$ solution of iron (II) sulfate.

(a) Write an equation for the reaction between potassium dichromate solution and the iron(II) sulfate solution.

[2 marks]

(b) The following titration results were obtained. Complete the table.

	1	2	3	4
Final volume (mL)	17.56	33.50	18.53	34.43
Initial volume (mL)	0.50	17.56	2.55	18.53
Titre				

[1 mark]

(c) Calculate the concentration of ethanol in the blood in (i) mol L^{-1} and (ii) g L^{-1}

[8 marks]

(d) The legal limit for ethanol in the blood is 50 mg per 100 mL of blood. Was this blood sample under or over the limit? (You must show reasoning).

[2 marks]

2004 Part 1

8. For the reaction



- (a) $\text{Au}^+(\text{aq})$ disproportionates.
- (b) $\text{Au}^{3+}(\text{aq})$ is a reducing agent.
- (c) $\text{Au}(\text{s})$ is oxidised.
- (d) None of (a), (b) or (c) is true.

9. An electrolytic cell with inert electrodes was operated in turn with each one of the following electrolyte solutions.

- I. 1 mol L⁻¹ CuSO₄
- II. 1 mol L⁻¹ H₂SO₄
- III. 1 mol L⁻¹ NaOH
- IV. 1 mol L⁻¹ NaCl

For which of the solutions would hydrogen gas be produced at the cathode and oxygen gas at the anode?

- (a) I, II, III and IV
 - (b) II only
 - (c) II and III only
 - (d) II, III and IV only
11. Which one of the following pairs of substances will react together when mixed?
- (a) Cl₂ + Cu²⁺
 - (b) Ni²⁺ + Cu
 - (c) Ni²⁺ + Zn
 - (d) Zn + Cl⁻

2004 Part 2

11 Sketch an electrolytic cell having a Cu cathode, a Pt (inert) anode and an electrolyte of 1 mol L⁻¹ CuSO₄. On your sketch, show the movement of ions and electrons.

4 marks]

Write an equation for the reaction occurring at each electrode.

Anode	
Cathode	

[2 marks]

Describe what you would observe during operation of the cell.

2005 Part 1

15. In which one of the following does manganese have an oxidation state of +6?

- (a) Mn₂O₃
- (b) MnO₂
- (c) MnO₄²⁻
- (d) MnO₄⁻

16. What is the change in the oxidation number of bromine in the following reaction?

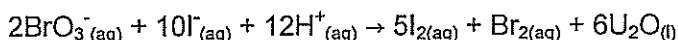

- (a) +7 to 0
- (b) +7 to -1
- (c) +5 to 0
- (d) +5 to -1

17. In which one of the following pairs do the underlined elements have the same oxidation number?

- (a) Cr₂O₇²⁻ and CrO₄²⁻
- (b) HF and MgH₂
- (c) H2O and H2O₂
- (d) NO₂ and HNO₃

20. A mixed solution containing both 1 mol L⁻¹ ZnSO₄ and 1 mol L⁻¹ CuSO₄ was electrolysed in an electrolytic cell using inert electrodes. Which one of the following statements is correct?

- (a) Copper is produced at the cathode and zinc is produced at the anode.
- (b) Copper is produced at the cathode and oxygen gas is produced at the anode.
- (c) Hydrogen gas is produced at the cathode and oxygen gas is produced at the anode.
- (d) Zinc is produced at the cathode and oxygen gas is produced at the anode.

29. In a sample of ground water, iron in the form of Fe^{2+} was found to have a concentration of $9.00 \times 10^{-3} \text{ mol L}^{-1}$. Assuming the density of the water sample is 1.00 g mL^{-1} , what is the concentration of Fe^{2+} expressed in ppm?
- 0.502 ppm
 - 9.00 ppm
 - 50.2 ppm
 - 502 ppm

2006 Part 1

16. An electrochemical cell has a positive value of E° . Which one of the following statements about the two half cells forming the cell is true?
- Both half cells must have positive standard reduction potentials.
 - The cathode half-cell must have a positive standard reduction potential, while the anode half-cell must have a negative standard reduction potential.
 - At least one of the half cells must have a positive standard reduction potential.
 - Both half cells may have a negative standard reduction potential.
21. A garden water feature made of cast iron was observed to be severely corroded. Which one of the following measures would decrease the rate of corrosion?
- Attach a piece of copper to the iron.
 - Attach a piece of magnesium to the iron.
 - Apply an anodic current to the iron.
 - Add bleach (sodium hypochlorite) to the water.

2006 Part 2

1. Write the equation for the reaction that occurs in each of the following procedures. If no reaction occurs write 'no reaction'. Following this, describe in full what you would observe in each case, including any colours, odours, precipitates (give the colour), gases evolved (give the colour or describe as colourless). If no change is observed, you should state this.

- (a) Barium chloride solution is added to sodium phosphate solution.

Equation

Observation

[3 marks]

- (b) Dilute sulfuric acid is added to copper metal.

Equation

Observation

[3 marks]

- (c) A small amount of chlorine gas is added to potassium bromide solution.

Equation

Observation

[3 marks]

2006 Part 3

1. When concentrated nitric acid is added to copper, nitrogen dioxide gas is produced. This reaction can be represented by the following unbalanced equation

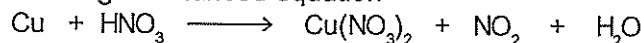

- Balance this equation.
- If 4.56 g of copper is added to 120.0 mL of 5.55 mol L^{-1} solution of nitric acid: Identify the limiting reagent.
- What volume of NO_2 is formed at 25°C and 100 kPa ?
- How many moles of excess reactant is left after the reaction? [9 marks]

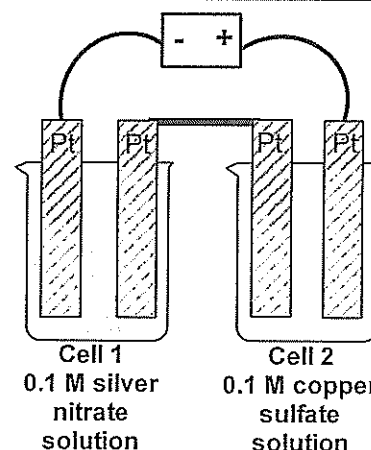

3. A steady current is passed through two electrolytic cells as shown in the diagram below:

After 126 minutes, 4.50 g of silver is precipitated at the cathode of Cell 1.

- Calculate the mass of copper precipitated in Cell 2.
- Identify the gas produced at the anode of each cell. Write an equation to represent the formation of that gas.
- Calculate the total volume of gas produced in both cells at S.T.P.

[11 marks]

5. The amount of ethanol in wine can be determined by adding a known excess volume of potassium permanganate to the wine and then titrating the left-over KMnO_4 with oxalic acid.

100.0 mL of 0.255 mol L^{-1} KMnO_4 solution was added to 8.00 mL of white wine and made up to 250.0 mL with distilled water. 20.0 mL samples of the treated wine were then titrated with a $0.0504 \text{ mol L}^{-1}$ solution of oxalic acid dihydrate ($\text{C}_2\text{H}_2\text{O}_4 \cdot 2\text{H}_2\text{O}$).

The following results were obtained.

Titration results	Trials			
	1	2	3	4
Final volume	29.4	26.45	27.30	24.60
Initial volume	2.6	3.20	4.35	1.50
Titre				

The relevant equations are given below:

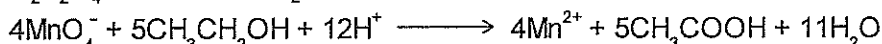
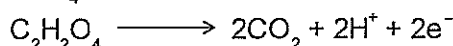

- Write a balanced equation for the reaction between potassium permanganate and oxalic acid. Using the equations provided:
- Determine the concentration of ethanol in the original wine in mol L^{-1}
- Determine the concentration of ethanol in the wine in g L^{-1} .

[11 marks]

2007 Part 1

17. Consider the following equation:

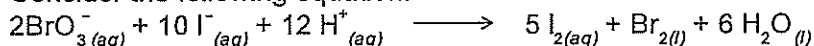

For this reaction, which one of the following is true?

- BrO_3^- is the reducing agent.
- H^+ is reduced.
- I^- is the oxidising agent.
- BrO_3^- is reduced.

18. Consider the statements about the following reaction:



- H_2O_2 is reduced.
- H_2O_2 is oxidised.
- H_2O_2 acts as a reducing agent.
- This is not a redox reaction.

Which of the above statements are true?

- IV only
- II and III only
- I only
- I, II and III only

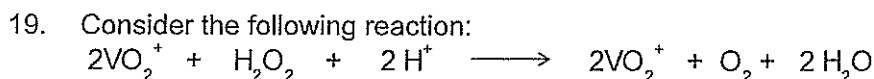

Which one of the following statements is true for this reaction?

- (a) The VO_2^+ is reduced and the H^+ is oxidised.
- (b) The H^+ is reduced and the H_2O_2 is oxidised.
- (c) The VO_2^+ is the oxidising agent and the H^+ is the reducing agent.
- (d) The VO_2^+ is reduced and the H_2O_2 is oxidised.

20. An electrolytic cell consists of steel electrodes immersed in 1.00 mol L^{-1} nickel(II) chloride solution. Which of the following reactions is most likely to occur at the cathode?

- (a) $\text{Ni}_{(aq)}^{2+} + 2\text{e}^- \longrightarrow \text{Ni}_{(s)}$
- (b) $2\text{H}_2\text{O}_{(l)} + 2\text{e}^- \longrightarrow \text{H}_{2(g)} + 2\text{OH}_{(aq)}^-$
- (c) $\text{Fe}_{(s)} \longrightarrow \text{Fe}_{(aq)}^{2+} + 2\text{e}^-$
- (d) $2\text{Cl}_{(aq)}^- \longrightarrow \text{Cl}_{2(g)} + 2\text{e}^-$

21. A Galvanic cell consists of an $\text{Ag}/\text{Ag}^+_{(aq)}$ half-cell coupled with a $\text{Co}/\text{Co}^{2+}_{(aq)}$ half-cell as shown in the diagram below:

Under standard conditions, what voltage would be generated by this cell?

- (a) 1.88 V
- (b) 1.32 V
- (c) 1.08 V
- (d) 0.52 V

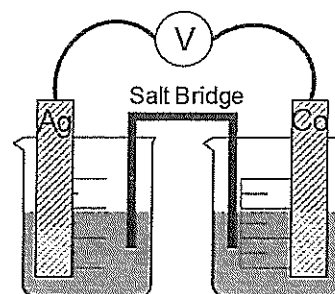

1.0 mol L⁻¹ AgNO₃ 1.0 mol L⁻¹ Co(NO₃)₂

22. Which one of the following statements is correct?

- (a) The corrosion of iron is a redox reaction in which iron is oxidised.
- (b) A sacrificial anode is more easily reduced than iron.
- (c) Cathodic protection prevents rusting by excluding oxygen.
- (d) Painting of iron prevents corrosion because the paint is more readily oxidised than the iron.

2007 Part 2

1. Write the equation for the reaction that occurs in each of the following procedures. If no reaction occurs write -no reaction-. Following this, describe in full what you would observe in each case, including any colours, odours, precipitates (give the colour), gases evolved (give the colour or describe as colourless). If no change is observed, you should state this.

(b) Zinc dust is added to a solution of gold(III) chloride.

Equation

Observation

[3 marks]

2008 Part 1

17. In which of the following is vanadium in its highest oxidation state?

- a) VO_2^+
- b) VO^{2+}
- c) VO_2
- d) V_2O_3

19. An electrolytic cell consists of nickel electrodes in a $1.00 \text{ mol L}^{-1} \text{ CuCl}_2$ solution. Under standard conditions, what products would be expected at the anode and cathode?

Anode Product Cathode Product

- (a) $\text{Cl}_{2(g)}$ $\text{Cu}_{(s)}$
 (b) $\text{O}_{2(g)}$ $\text{Cu}_{(s)}$
 (c) $\text{O}_{2(g)}$ $\text{H}_{2(g)}$
 (d) $\text{Ni}^{2+}_{(aq)}$ $\text{Cu}_{(s)}$

2008 Part 2

Question 1 (12 marks)

Write the equation for the reaction that occurs in each of the following procedures. If no reaction occurs, write 'no reaction'. Following this, describe in full what you would observe in each case, including any colours, odours, precipitates (give the colour), gases evolved (give the colour or describe as colourless). If no change is observed, you should state this.

- (a) Chlorine gas is bubbled through a sodium iodide solution. (3 marks)
 Equation Observation

- (d) Solid sodium carbonate is added to an excess of acetic acid solution. (3 marks)
 Equation Observation

Question 8 (7 marks)

Consider the following diagram of an electrochemical cell consisting of a potassium nitrate salt bridge and half cells containing:

- I a 1.0 mol L^{-1} nickel(II) chloride solution and a nickel electrode;
 II a 1.0 mol L^{-1} chromium(III) chloride solution and a chromium electrode.

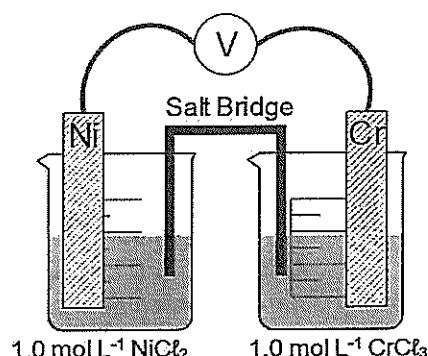

- (a) Label the cell diagram, showing anode, cathode, direction of electron flow and direction of flow of ions (both positive and negative) in the salt bridge. (3 marks)
 (b) Write an equation for the overall reaction in the cell. (2 marks)
 (c) Calculate the EMF (voltage) for the cell at standard conditions. (1 mark)
 (d) Why would a potassium carbonate salt bridge be an inappropriate choice for this electrochemical cell? (1 mark)
 (e)

2009 Part 1

22. Which one of the following will be true for this cell?

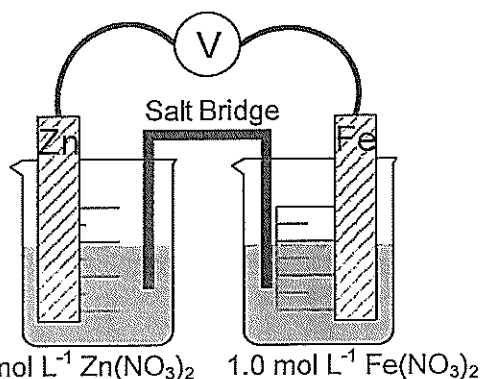

- (a) The mass of the zinc electrode will increase.
 (b) Electrons will flow from the zinc electrode to the iron electrode.
 (c) The concentration of Fe^{2+} ions in the electrolyte will increase.
 (d) Iron will be deposited on the zinc electrode.

23. Which one of the following will be the closest to the cell EMF, at 25°C?
- 0.32 V
 - 1.20 V
 - 1.53 V
 - 1.59 V
24. If the following aqueous solutions were electrolysed using inert electrodes, under standard conditions which one would produce a metal at the cathode and oxygen gas at the anode?
- $\text{Pb}(\text{NO}_3)_2$
 - NaOH
 - CaCl_2
 - ZnI_2

2009 Part 2

Question 8 (8 marks)

- (a) Pieces of zinc attached to the steel hull of a ship help protect it from corrosion. This is shown below. (3 marks)

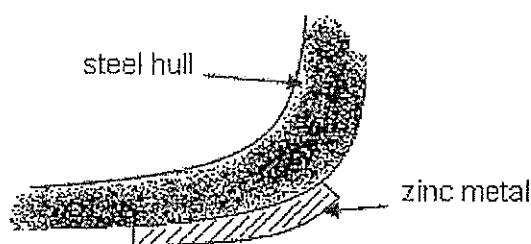

- Complete the diagram by labelling the anode and the cathode.
 - It was suggested that copper replace the zinc. Explain how this will affect the corrosion prevention.
- (b) Cathodic protection is a method by which corrosion of steel structures is minimised. A steel jetty can be protected by electrically connecting it to a piece of scrap iron and connecting both to a low voltage power supply set to 0.5 volt, as shown in the diagram below. (5 marks)

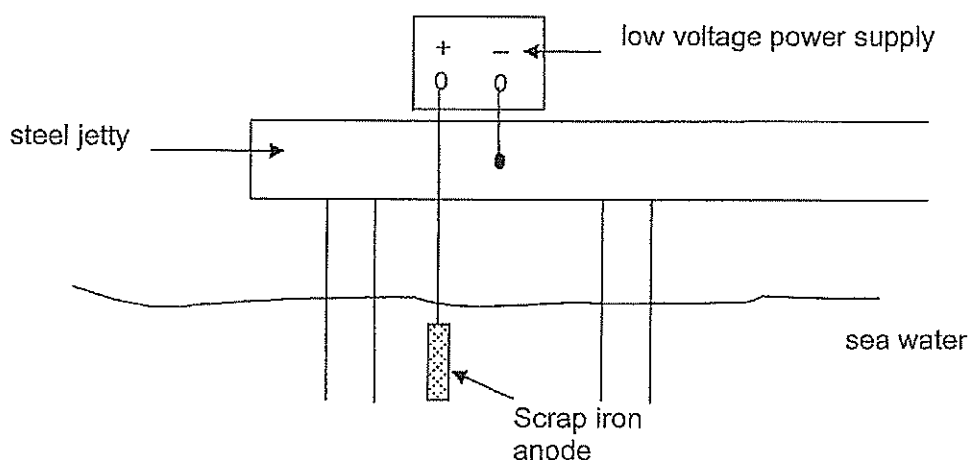

- Write the equation for the reaction occurring at the anode and the reaction occurring at the cathode.
- If a piece of copper is used as the anode instead of the scrap iron, explain how this will affect this method of corrosion protection.

2009 Part 3

Question 5

(10 marks)

In order to analyse the iron content of a ferrochrome alloy, a solution of potassium permanganate was standardised and then titrated against the iron present in a sample of the alloy.

Standardisation Procedure

16.58 g of hydrated ammonium iron(II) sulfate, $\text{Fe}(\text{NH}_4)_2(\text{SO}_4)_2 \cdot 6\text{H}_2\text{O}$, was dissolved in approximately 50 mL of distilled water and made up to 250.0 mL in a volumetric flask. 25.00 mL aliquots of this solution were acidified and titrated against potassium permanganate solution with a concentration of approximately 0.05 mol L^{-1} . The following results were obtained:

Titration result	Trials (mL)			
	1	2	3	4
Final volume	14.72	29.12	43.42	16.47
Initial volume	0.02	14.72	29.12	2.15
Titre				

Analysis of Alloy

5.900 g of alloy was dissolved in approximately 100 mL of hot sulfuric acid, which dissolved the iron to form Fe^{2+} ions in solution. The resulting solution was filtered and made up to 250.0 mL with distilled water. 20.00 mL aliquots of this solution required an average titre of 13.40 mL of the standardised potassium permanganate solution for complete reaction.

Calculate the percentage, by mass, of iron in the alloy.

2010 SP Part 1

14. Which of the four elements (Fe, S, O or Cr) shown in bold below has the highest oxidation state?

- (a) **Fe** Cl_3
- (b) Na_2 **S** O_3
- (c) K_2 **Cr** $_2\text{O}_7$
- (d) **Cr** $_2\text{O}_3$

15. A short rod of silver metal dips into a 1.0 mol L^{-1} solution of silver nitrate to create an Ag/Ag^+ half-cell. Similarly, a rod of lead metal dips into a 1.0 mol L^{-1} solution of lead(II) nitrate. The two rods are joined by a piece of copper wire. A salt bridge of ammonium nitrate, as shown in the diagram below, joins the two solutions.

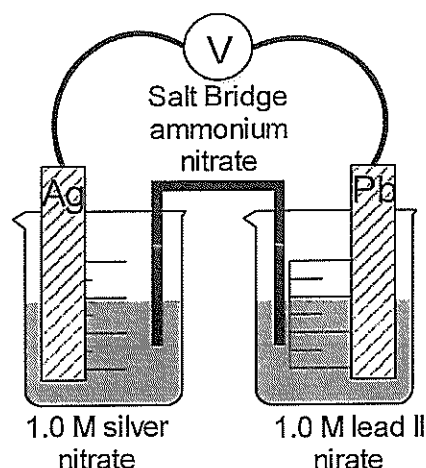

Which one of the following will occur?

- (a) Lead deposits from solution onto the lead rod.
 - (b) Electrons flow through the wire from the lead rod to the silver rod.
 - (c) Nitrate ions migrate through the salt bridge from the Pb/Pb^{2+} half-cell to the Ag/Ag^+ half-cell.
 - (d) The silver rod starts to dissolve.
16. Chlorine gas is bubbled through a solution of a salt, and the solution turns brown. A separate solution of the same salt is added to a solution of lead(II) nitrate, and a bright yellow precipitate is formed. Which of the following is the most likely identity of the ion causing the colour changes?
- (a) iron(III)
 - (b) bromide
 - (c) iodide
 - (d) chromate

2010 SP Part 2

Question 31 (4 marks)

Write observations for any reactions that occur in the following procedures. In each case describe in full what you would observe, including any colours, odours, precipitates (give the colour), gases evolved (give the colour or describe as colourless). If no change is observed, you should state this.

- (a) A slight excess of iron (II) sulfate solution is mixed with acidified potassium permanganate solution. (2 marks)

Question 36

(10 marks)

Corrosion is the process of metal oxidation and, while in many cases it is a destructive and costly process, in the case of some metals, the corrosive process can be beneficial in that it provides a protective coating on the metal. This is the case for aluminium; the aluminium is oxidised when exposed to the oxygen and water vapour in the atmosphere to form a thin layer of its hydroxide.

- (a) Write the oxidation and reduction half equations and the overall equation for the oxidation of aluminium. (3 marks)

- (i) Oxidation
(ii) Reduction
(iii) Overall

The aluminium hydroxide initially formed in this process dehydrates to give a continuous layer of insoluble aluminium oxide.

- (b) Consider the above information and explain how the corrosive process forms a protective layer. Use a reaction equation or equations to aid your explanation. (2 marks)

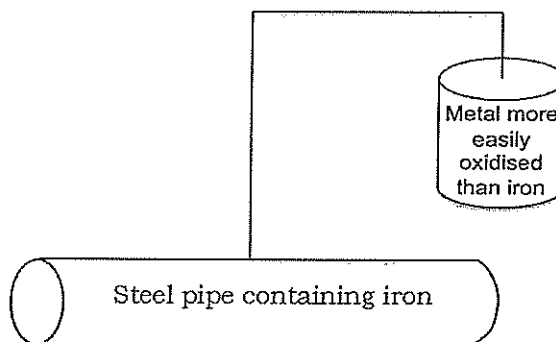

Corrosion can be prevented by cathodic protection, a method often used to protect iron in steel in pipelines that are buried. A metal that is more readily oxidised than iron is connected by a wire to the pipe that must be protected from corrosion, as indicated in the diagram below. This metal then acts as an anode in a redox reaction. Aluminium is a metal that may theoretically be used for cathodic protection of iron.

- (c) By referring to the Standard Reduction Potential table, suggest one other metal that may be connected to a steel pipe as a cathodic protectant. (1 mark)
- (d) Explain why, in practice, aluminium may not be very effective as a cathodic protectant. (1 mark)
- (e) If copper was connected to the steel pipe, the surface of the copper would be cathodic and the iron in the steel anodic. The cathodic reaction on the surface of the copper and the anodic reaction of the iron are shown below.

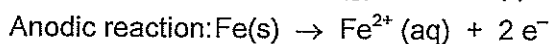
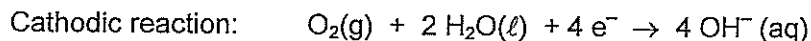

If 500.0 kg of iron corroded in the steel pipe, what mass of H_2O reacts at the surface of the copper?

(3 marks)

2010 Part 1

10. Which one of the four elements (Cl, Cr, P, Mn) underlined below has the lowest oxidation state?

- (a) HClO₂
(b) K₂CrO₄
(c) Na₃PO₄
(d) KMnO₄

11. Which of the following are redox reactions?

- I. $N_2 + 3 H_2 \rightarrow 2 NH_3$
II. $CaCO_3 + 2 HCl \rightarrow CaCl_2 + H_2O + CO_2$
III. $Zn + 2 HCl \rightarrow ZnCl_2 + H_2$
IV. $S + O_2 \rightarrow SO_2$

- (a) equations I, II, III and IV
(b) equations I, III and IV only
(c) equations II, III and IV only
(d) equation IV only

12. In which one of the following will a metal displacement reaction occur?
- a zinc rod is dipped in a 1.0 mol L^{-1} solution of sodium sulfate
 - a copper rod is dipped in a 1.0 mol L^{-1} solution of cobalt(II) nitrate
 - a silver rod is dipped in a 1.0 mol L^{-1} solution of gold(III) nitrate
 - a tin rod is dipped in a 1.0 mol L^{-1} solution of manganese(II) sulfate

2010 Part 2

Question 35 (5 marks)

Concentrated sulfuric acid can behave as an oxidising agent. Depending upon conditions, it can react in one of three ways to form

- sulfur dioxide gas;
- hydrogen sulfide gas; or
- elemental sulfur.

- (a) Write half-equations showing each of these three possible reactions.

Reduction half equation
Oxidation half equation
Overall redox equation

(3 marks)

Question 36 (9 marks)

A Galvanic cell consists of a tin electrode in a solution of 1.0 mol L^{-1} tin(II) nitrate, to create a Sn/Sn^{2+} half-cell, and a similarly constructed half-cell composed of a chromium electrode in a solution of 1.00 mol L^{-1} chromium(III) nitrate. The two electrodes are joined by a piece of copper wire. A salt bridge, as shown in the diagram below, joins the two solutions

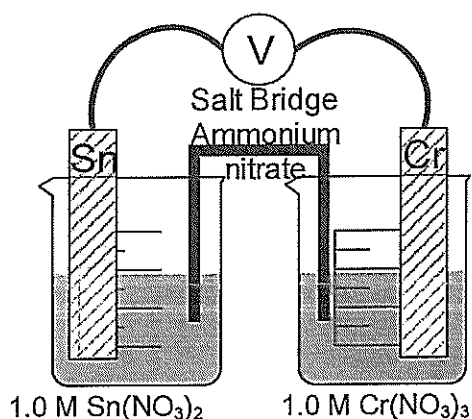

- On the diagram, label
 - the anode
 - the direction of electron flow
 - the direction of cation flow in the salt bridge.

(3 marks)
- Write the balanced anode and cathode reactions. (2 marks)
- Would sodium carbonate be suitable as a salt for the salt bridge? Explain. (2 marks)
- Why does the rate of production of electrical current from an electrochemical cell decrease as it operates? (1 mark)
- During the operation of an electrochemical cell, why is it important that the anode and cathode do not come into contact with each other? (1 mark)

Question 37 (12 marks)

A blast furnace is a large furnace operated at very high temperatures to convert iron(III) oxide (in iron ore) to iron using carbon monoxide, which is itself converted to carbon dioxide during the process.

- Write the equation for the reaction of iron(III) oxide with carbon monoxide. (1 mark)
- Identify the oxidant and reductant in the above process. (1 mark)
- 1.00 tonne of iron ore containing 96.5% iron(III) oxide is fed into the blast furnace with $2.70 \times 10^6 \text{ L}$ of carbon monoxide at 113 kPa pressure and 1986°C .

Note: 1 tonne = 1×10^6 g

- (i) Determine the limiting reactant for this reaction. (4 marks)
(ii) What mass of iron is theoretically produced in this reaction? (2 marks)
(iii) Calculate the mass of the reactant in excess. (3 marks)
(d) If 5.56×10^{-1} tonne of iron is actually produced, what is the overall percentage yield of the process? (1 mark)

The Redox Answers

1990 Part 1 Answers

12 a

1990 Part 2 Answers

11a 1.36V 11b $\text{H}_2(\text{g}) \rightarrow 2\text{H}^+(\text{aq}) + 2\text{e}^-$ 11c $\text{Cl}_2 + 2\text{e}^- \rightarrow 2\text{Cl}^-$
11d hydrochloric acid 11e clockwise

1991 Part 1 Answers

9. c 19. d 21 a

1991 Part 2 Answers

- 1a. Equation $2\text{I}^-(\text{aq}) + \text{Cl}_2(\text{g}) \rightarrow 2\text{Cl}^-(\text{aq}) + \text{I}_2(\text{aq})$
Observation Colourless (pale green) gas is bubbled into a clear colourless liquid that turns yellow/brown
9a self-protecting with an aluminium oxide coating
9b the aluminium being more active protected the iron from oxidation and the aluminium near the bolts was lost

1991 Part 3 Answers

3. $5\text{Fe}^{2+}(\text{aq}) + \text{MnO}_4^-(\text{aq}) + 8\text{H}^+(\text{aq}) \rightarrow \text{Mn}^{2+}(\text{aq}) + 5\text{Fe}^{3+}(\text{aq}) + 4\text{H}_2\text{O}(\text{l})$
 $\text{MnO}_4^-: n=c \times v = 0.101 \times 0.02645 = 0.00267145\text{mol}$
So in a 25mL portion there was $5 \times 0.00267145 \text{ mol of Fe}^{2+} = 0.01335725\text{mol}$
So in 100mL there was 0.053429mol
Mass = $n \times M = 0.053429 \times 56 = 2.983742505\text{g}$
The original was 3.20g so the percentage is $2.983742505/3.20 \times 100 = 93.2\%$ (3 sf)

1992 Part 1 Answers

16 a 26 b

1992 Part 3 Answers

2. (a) 1.04g of lead formed
(b) (i) 0.095mol/L .
(ii) 0.20mol/L .
(c) The lead nitrate contributes 2 NO_3^- for each lead and some of the lead was removed.
8. $2\text{Br}^- \rightarrow \text{Br}_2 + 2\text{e}^-$ $2\text{BrO}_3^- + 10\text{e}^- + 12\text{H}^+ \rightarrow 6\text{H}_2\text{O} + \text{Br}_2$
 $10\text{Br}^- + 2\text{BrO}_3^- + 12\text{H}^+ \rightarrow 6\text{Br}_2 + 6\text{H}_2\text{O}$
11a. Zn and Cu^{2+} 11b to the left 11c SO_4^{2-} 11d K^+ 11e zinc and copper sulfate

1993 Part 1 Answers

24 b 25 b

1993 Part 2 Answers

- 3 a E° for the Cu^{2+}/Cu is > 0 while for many metals it is < 0
b insoluble CaSO_4 coats the CaCO_3

14

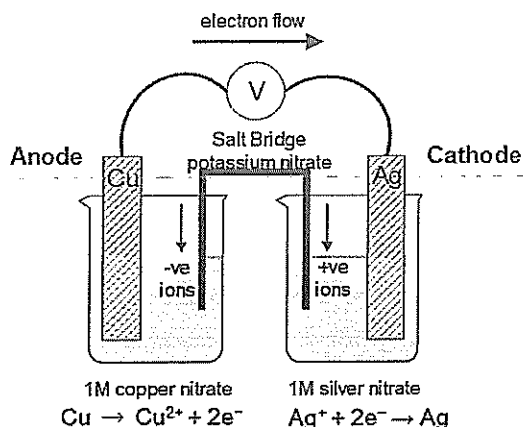

1994 Part 1 Answers

16 e 17 a 18 e

1994 Part 2 Answers

- 12 a direct current power source
 b left
 c copper II sulfate
 d It dissolves from electrode B and deposits on electrode A
 e it dissolves and stays in solution
 f it falls to the bottom

1995 Part 1 Answers

25 d

1996 Part 1 Answers

19 c 20 a 29 d

1996 Part 2 Answers

13 $2\text{H}^+ + 2\text{e}^- \longrightarrow \text{H}_2$, $\text{Cu} \longrightarrow \text{Cu}^{2+} + 2\text{e}^-$
 by adding a lot of NH_3 to give a visible blue, use a Pt electrode

1997 Part 1 Answers

20 b 21 b

1997 Part 2 Answers

- 8 oxidation $2\text{Br}^- \longrightarrow \text{Br}_2 + 2\text{e}^-$
 Reduction $2\text{BrO}_3^- + 12\text{H}^+ + 10\text{e}^- \longrightarrow \text{Br}_2 + 6\text{H}_2\text{O}$
 Redox equation $5\text{Br}^- + \text{BrO}_3^- + 6\text{H}^+ \longrightarrow 3\text{Br}_2 + 3\text{H}_2\text{O}$
- 9 i +6 sodium hydroxide solution
 ii +3 a solution containing Fe(II) sulphate and sulphuric acid

1998 Part 1 Answers

6 c 21 e 28 c

1998 Part 2 Answers

- 5 H_2O_2 : has disproportionated
 MnO_2 : has acted as a catalyst – no change
 Gas produced: oxygen
- 8 Oxidation half equation $\text{TeO}_2 + 2\text{H}_2\text{O} \longrightarrow \text{TeO}_4^{2-} + 4\text{H}^+ + 2\text{e}^-$
 Reduction half equation $\text{CrO}_7^{2-} + 14\text{H}^+ + 6\text{e}^- \longrightarrow 2\text{Cr}^{3+} + 7\text{H}_2\text{O}$
 Redox equation $\text{CrO}_7^{2-} + 3\text{TeO}_2 + 2\text{H}^+ \longrightarrow 3\text{TeO}_4^{2-} + 2\text{Cr}^{3+} + \text{H}_2\text{O}$

1999 Part 1 Answers

12 b 18 c 19 c

1999 Part 2 Answers

- 10 (a) $\text{Ni}^{2+}_{(\text{aq})} + 2\text{e}^- \longrightarrow \text{Ni}$
 (b) towards the right.
 (c) $-0.26 + 0.76 = 0.50\text{V}$

1999 Part 3 Answers

4. (a) 2.5 mol – seems too easy.
 (b) 0.0015mol
 (c) 192ppm
 (d) To ensure that all the SO_3^{2-} is converted to SO_2
 (e) Change from colourless to purple

2000 Part 1 Answers

8 d 9 b 12 b 13 a

2001 Part 1 Answers

13 a or d 14 a

2002 Part 1 Answers

17 b 18 a 20 d

2003 Part 1 Answers

15 c 20 a 21 b 22 c
 23 c 30 c

2003 Part 2 Answers

7. 1 mark each equation

$\text{NaCl}(\ell)$

anode: $2 \text{Cl}^-(\ell) \rightarrow \text{Cl}_2(\text{g}) + 2 \text{e}^-$

cathode: $\text{Na}^+(\ell) + \text{e}^- \rightarrow \text{Na}(\ell)$

$\text{NaCl}(\text{aq})$

anode: $2 \text{H}_2\text{O}(\ell) \rightarrow \text{O}_2(\text{g}) + 4 \text{e}^- + 4 \text{H}^+(\text{aq})$

cathode: $2 \text{H}_2\text{O}(\ell) + 2 \text{e}^- \rightarrow \text{H}_2(\text{g}) + 2 \text{OH}^-(\text{aq})$

2003 Part 3 Answers

5. $6 \text{Fe}^{2+}(\text{aq}) + \text{Cr}_2\text{O}_7^{2-}(\text{aq}) + 14 \text{H}^+(\text{aq}) \rightarrow 6 \text{Fe}^{3+}(\text{aq}) + 2 \text{Cr}^{3+}(\text{aq}) + 7 \text{H}_2\text{O}$
 (b) Titre 17.06 15.94 15.98 15.90
 (c) $1.53 \times 10^{-2} \text{ mol L}^{-1}$ and 0.704 g L^{-1}
 (d) 70.42 mg over

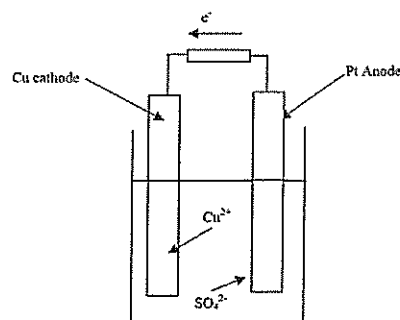
**2004 Part 1 Answers**

8 a 9 d 11 c

2004 Part 2 Answers

11 Anode $2\text{H}_2\text{O}(\ell) \rightarrow \text{O}_2(\text{g}) + 4\text{H}^+(\text{aq}) + 4\text{e}^-$

Cathode $\text{Cu}^{2+}(\text{aq}) + 2\text{e}^- \rightarrow \text{Cu}(\text{s})$

The copper cathode would grow larger and be salmon pink while the solution would become less blue.

2005 Part 1 Answers

15 c 16 c 17 a 20 b
 29 d

2006 Part 1 Answers

16 d 21 b

2006 Part 2 Answers

- 1 (a) $3 \text{Ba}^{2+}(\text{aq}) + 2 \text{PO}_4^{3-}(\text{aq}) \rightarrow \text{Ba}_3(\text{PO}_4)_2(\text{s})$
 2 [colourless] solutions react to form a white precipitate. (1 mark)
 (b) No reaction (2 marks)
 No change observed or no visible reaction or NYR (1 mark)
 (c) $2 \text{Br}^-(\text{aq}) + \text{Cl}_2(\text{g}) \rightarrow \text{Br}_2(\ell \text{ or } \text{aq}) + 2 \text{Cl}^-(\text{aq})$ (2 marks)
 [Greenish gas is bubbled into colourless solution] Solution turns reddish brown (1 mark)

2006 Part 3 Answers

- 1 a $\text{Cu} + 4 \text{HNO}_3 \rightarrow \text{Cu}(\text{NO}_3)_2 + 2 \text{NO}_2 + 2 \text{H}_2\text{O}$
 b Cu
 c 3.602 L NO_2
 d 0.379 mol HNO_3
 3 a 1.325 g Cu

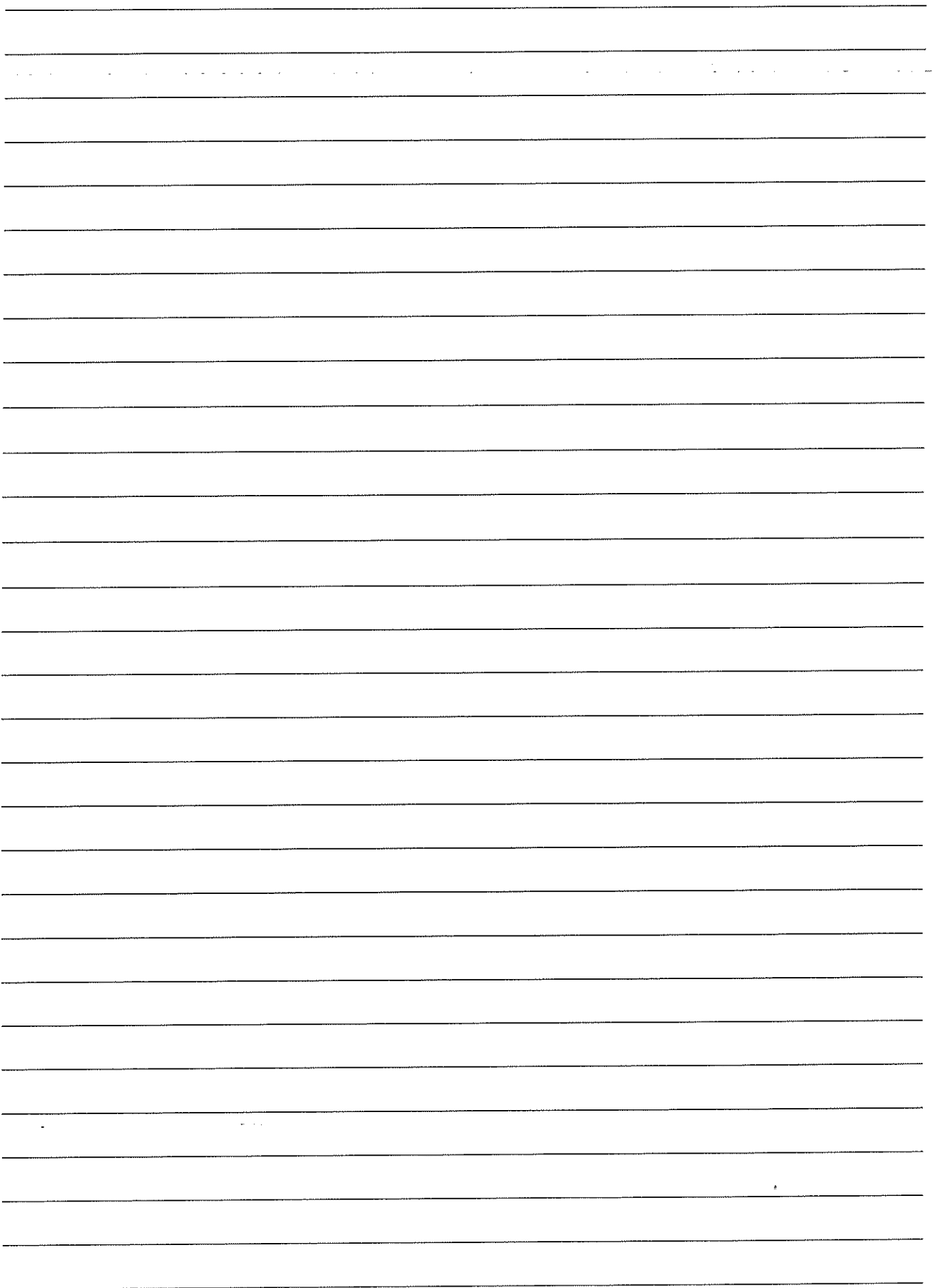

ACHIEVE SUCCESS AT SCHOOL

All subjects - All levels - All ages - All areas

ACADEMIC GROUP has helped students achieve success through excellence in education since 1986

We are the WACE Revision Specialists

ACADEMIC TASK FORCE and ACADEMIC ASSOCIATES
will help you maximise your performance and achieve success

Excellent results were achieved by students who have attended our courses in 2015

5 General Exhibitions
5 Course Exhibitions
47 Certificates of Distinction
140 Certificates of Commendation

Guaranteed performance and quality
through expert teaching by qualified professionals.

Boost your confidence and increase your performance now

For more information please contact us

Phone: 9314 9500

Email: learn@academictaskforce.com.au

Visit Academic Task Force website: www.academictaskforce.com.au

Visit Academic Associates website: www.academicassociates.com.au

ACADEMIC GROUP

Educational Consultants & Publishers

ABN 50 151 087 286



**ACADEMIC
ASSOCIATES**

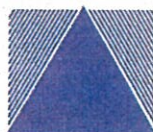

**ACADEMIC
TASK FORCE**

Providing Excellence in Education since 1986